

Game Design Document

Clapcom Studios - Project Alien



TABLE OF CONTENTS

1. Game Overview	4
1.1 Core Concept	4
1.2 Game Pillars	4
1.3 Unique Selling Points	4
1.4 Genre	4
1.5 Target Audience	5
2. Story	6
2.1 Filmography context	6
2.2 Plot Summary	7
2.3 Characters	7
2.3.1 Protagonist	7
2.3.2 Antagonist(s)	11
2.3.3 Supporting Characters	12
2.4 Setting	14
2.4.1 Key Locations	14
2.4.2 World History and Lore	15
2.4.3 Start setting	16
2.5 Story milestones	17
2.6 Dialogues	17
2.6.1 Dialogue types	17
2.6.2 Dialogues guide	18
2.6.3 Dialogue Wireframe	19
2.6.4 Game Dialogues	19
2.7 CutScenes	22
3. Gameplay	23
3.1 Core Gameplay Loop	23
3.2 Core Mechanics and Features	23
Camera	23
Base Teleporter	26
Extraction Teleporter	26
Weapons	27
Items	27
Altar	27
Equipment	28
Crafting	28

Item management	28
Movement system	28
Combat system	29
Extraction	29
Death	29
Heals	29
Save/Load	30
In-game pause	30
3.3 Stats and Characteristics	30
3.4 Character Mechanics and Controls	32
3.4.1 Skills	37
3.5 Inventory and Equipment	40
3.5.1 Item Slots	40
3.5.2 Equipment	41
3.6 Items and Crafts	42
3.6.1 Drops	42
3.6.2 Crafts	43
3.7 Crafting and Upgrading mechanics	45
3.7.1 Crafting Station (Caius)in	45
3.7.2 Upgrade Weapon Station	46
3.8 Objectives	47
3.8.1 Short-term Goals (within levels)	47
3.8.2 Long-term Goal (overall game)	47
4. Weapons	48
4.1 Firearms	49
4.2 Firearm Specialized in Area Damage	52
4.3 Plasma	56
4.4 Weapons Particles	60
5. Enemies	63
5.1 Facehugger	64
5.2 Drone Xenomorph	67
5.3 Xeno Spitter	70
5.4 Enemy rarities	74
5.5 Queen Xenomorph	75
6. Level Design	79
6.1 Game Graphs	79
6.2 Base/Spaceship	85
6.3 Level 1 - The Warehouse	87

6.4 Level 2 - The Lab	94
6.5 Level 3 - The Hatchery	100
6.6 Enemy encounters	105
6.7 Chest Items	106
6.8 Asset list	109
Base props	109
Base infrastructure	112
Lvl 1 props	116
Lvl 1 infrastructure	120
Lvl 2 props	125
Lvl 2 infrastructure	132
Lvl 3 props	137
Lvl 3 infrastructure	139
6.9 Assets Particles	142
7. User Interface (UI)	146
7.1 HUD (Head-Up Display)	146
7.2 Inventory	148
7.3 Crafting	151
7.4 Weapon Upgrade Station	154
7.5 Dialogue	158
7.6 Base Teleporter	159
7.7 Loading screens	162
7.8 Base Stash	164
7.9 Die Screen	165
7.10 Pause Screen	166
7.11 Global Game Menu Flow	167
8. Audio	170
8.1 Audio Pilar	170
8.2 Required assets	170
8.3 Planning	180
8.4 Integration & implementation	181

1. Game Overview

1.1 Core Concept

The main concept of our game is to merge the feeling of tension and terror of the Alien saga with the thrill of fast and intense gameplay of Diablo-like games. Players will take on the role of an elite soldier sent to an alien-infested planet to clear it of all hostile forms. The action focuses on multi-level raids, where players will have to explore, fight against saga enemies, manage their resources carefully to survive and not die in their attempt to discover the truth.

1.2 Game Pillars

- **World exploration:** It offers an immersive experience of exploration in a world surrounded by the terrifying and mysterious atmosphere of the Alien universe.
- **Fast paced combat:** Provide the player with intense combat, based on skill and reaction, facing hordes of Aliens in claustrophobic or large environments.
- **Inventory and items management:** The player must give importance to making strategic decisions about what objects to carry and how to manage them to survive the raids in the different scenarios. Or, to return to the ship to improve it and be able to continue advancing in the levels.

1.3 Unique Selling Points

- **Alien IP:** We want to take advantage of the popularity of the well-known Alien franchise to offer an authentic and immersive experience within this universe through a Diablo-like game style.
- **Extraction meets diablo-like:** Our game combines the thrill of resource mining with the addictive and intense gameplay of Diablo, offering a unique and captivating gaming experience.
- **Own engine:** This game is also unique as it has been developed with our exclusive game engine, ensuring optimal performance and unique customization possibilities.

1.4 Genre

Our video game will be Diablo-like for PC with extraction mechanics. Players will experience the addictive gameplay and thrill of fighting off hordes of Aliens in mystery and action-packed scenarios as they manage their resources and equipment in order to survive this exploration of a lost base.

1.5 Target Audience

The target audience of our game is fans of the Alien saga, mainly young adults between the ages of 25 and 35. This group of people enjoy the experience of farming and improving their characters, but they are not interested in the abusive amount of content typical of MMORPGs. This game offers a unique and addictive gaming experience in a limited time, perfect for gamers looking for excitement and challenge in a horror and sci-fi environment.

2. Story

2.1 Filmography context

This section is dedicated to give a more specific context about the films that will be used as a reference to develop the story of the videogame.

Alien: Resurrection

Scientists clone Ripley with the queen inside her and everything (the complete pack). They keep the adult queen Xenomorph on the ship.

They use people to create more aliens (they are very smart, but with an IQ that breaks schemes, crazy).

Ripley's clone is half Xenomorph, it has certain characteristics it shares with these critters (oh, and it's immortal).

Two Xenomorphs escape from where they were being hatched (surprise). The ones that break free kill many of the crew. Ripley, on the other hand, escapes from her cell and helps the rest to finish off the Aliens.

During the escape attempt many more of the crew and Xenomorphs die.

After many twists and turns they decide to crash the ship to Earth (people are really smart in this movie).

Ripley crashes, ending up with the Alien queen. We discover in this place that there is a mixture of Human-Alien, this new species kills without hesitation a single second to the queen, but not Ripley. They end up killing this new Xenomorph.

They end up on Earth, but it's kind of deserted post apocalyptic with no apparent life (less bad too, I tell you).

Prometheus

Weyland Corp. recruits a group of professionals to search for "our creator".

They go to a planet where they find a new dead humanoid alien species, and a black liquid that we will see will be important for this new trilogy (for now biology).

David (the android), makes a crew member drink this liquid diluted in alcohol without his knowledge.

This crew member has sex with his wife, after a few hours this man dies and the woman "gives birth" to a kind of alien squid.

On the other hand, David finds one of these humanoid aliens alive, they go to wake him up and it turns out that, oh surprise, he is hostile.

After an action sequence, the alien tries to leave the planet with a ship with his race's technology, the rest realize that if he leaves it will be the end of humanity and crash their own ship to destroy the alien's ship.

More action scenes.

The woman and the android go together to look for where these beings come from.

Alien: Covenant

A colonization ship receives an ion strike (or something like that). David (the android of this ship, the good one, the good person, the one with a heart, the one who dies) wakes up the people in charge of the ship. They see that they are very far from their destination, but they receive a message from a nearby planet, see the conditions of the planet and discover that it could be suitable for life.

They approach and organize an expedition. In this expedition, two of the crew are intoxicated with some black powder, this makes aliens come out from inside them, the usual, you know.

In the middle of the chaos comes the David from the previous movie (the bad guy, the one who has no heart, the one who is going to kill everyone) to rescue them, because surprise, surprise, this planet is the one they are heading to at the end of the previous movie, almost as if it were a sequel and had a plot thread.

It turns out that many years have passed since the previous one, and when David (the bad guy) arrives to this planet it was inhabited by many humanoid aliens, but he has the great idea of creating a massive genocide by throwing the black liquid on them.

In all these years, the android has been dedicated to study the aliens and create mutations. Like all the androids in the saga, he has a strange fixation with these beings.

When he learns that the people he has saved come with a crew of 2,000 colonists, the light bulb goes on.

The aliens from before are still on the loose and they come back for them. Action scenes against the aliens and against the aliens.

2.2 Plot Summary

Weyland-Yutani Corp. sends an expedition, a combat ship, to a planet they used as a secret laboratory. This lab, half staffed by humans and half by androids, was dedicated to researching Alien mutations and behavior.

As you progress you discover that the androids working on the research released the Aliens, thus wiping out almost all human life on the planet.

Your mission is to clear the planet of any hostile form, you do not know the purpose, nor the consequences of these actions. You are just following orders.

2.3 Characters

2.3.1 Protagonist

Who is the player?

The player is a creation from the laboratory, an experiment for a new technology developed there that enables combining human and Alien DNA.

Player's DNA, though, comes from Yutani, co-owner of the corporation. She's been trying to enlarge her fate in different ways seeking eternal life, you are just a consequence.

A brain chip implanted from birth, accumulated information about the character's behavior, personality, experiences, memories, or even skills. This chip is unique and the information cannot be copied from one chip to another, for the moment.

Raisen can die as many times as she want, as long as the chip is not damaged, that information can be relocated to a functional clone.

This lethal combination makes the player the perfect fit for this job, **obedient**, as she was trained to be, **discreet**, **expendable** and **deadly**.

General Information

Raisen: A clone of a human and Xenomorph hybrid, based on the project of the replication of Ripley 8 but with the objective of making a living weapon against aliens instead of recovering a Queen Xenomorph as in the case of coronel Ellen Ripley.

Physical Description

Raisen possesses an almost human anatomy with a height towering the two meters but with alien features showing her hybrid nature like metallic looking fangs instead of teeth, claws on her hands with black chitinous armor, and a long tail ended on a sharp stinger like those of a Xenomorph. She is very muscular although she isn't ripped, having a more agile figure more similar to athletes than weightlifters.

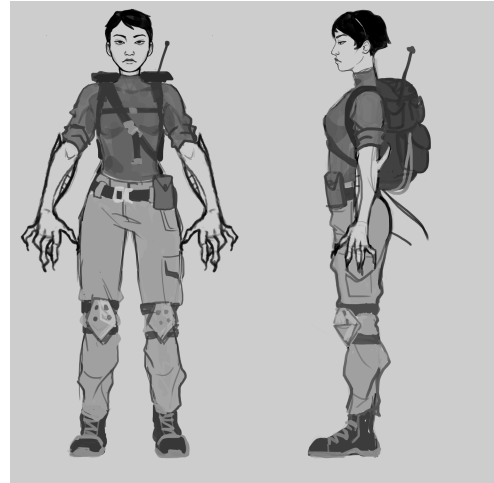

She has the hair black and short to “not hamper her in battle”. She has japanese traits due to her base human ADN being base of a japanese woman, having the epicentric fold in her eyes.

She wears militar clothes, with a camouflage t-shirt with short sleeves showing her mutant elbows. She wears long trousers with metal knees reinforcing and comfortable boots. She also wears a belt with small pouches for storing her grenades and a big backpack with a radio and a flashlight to carry all the possible elements she may gather on her expeditions.

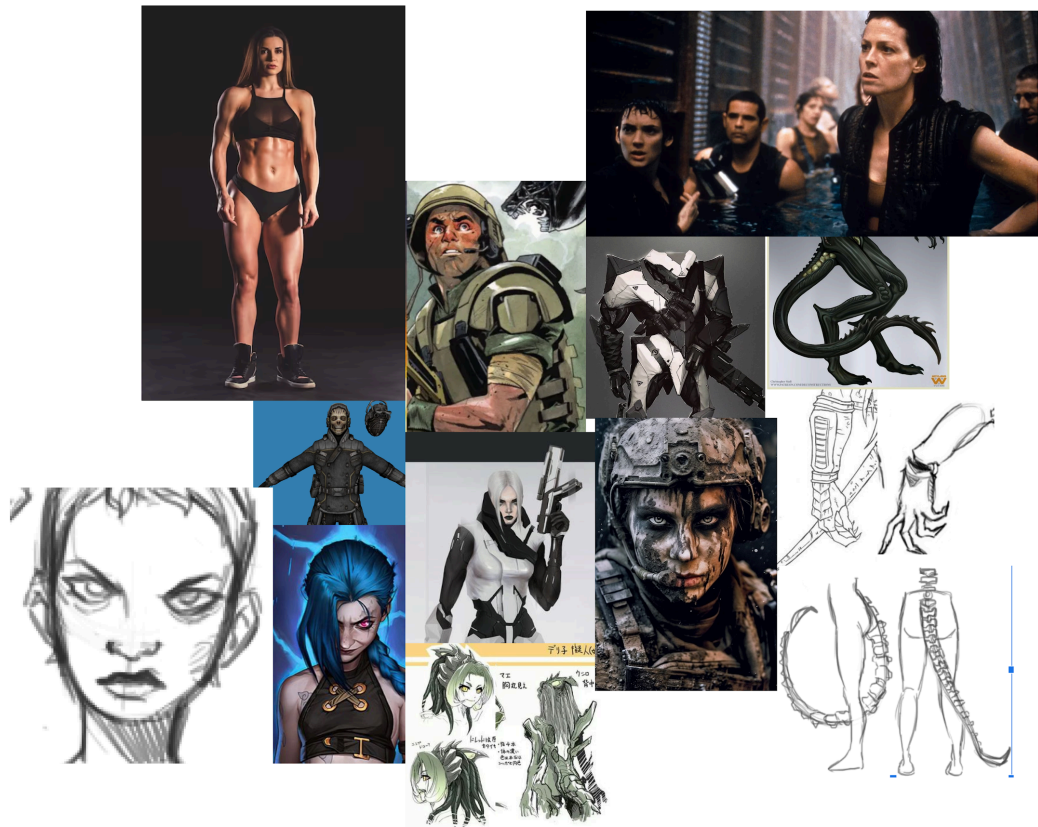

Character moodboard

TEXTURA CAMISETA

Color camiseta

COMENTARIO: NO ESTOY SEGURO SI QUE LOS COLORES VAYAN A COMBINAR BIEN

Color pantalon

Maybe con este patron?
Quizza es muy fumada

TEXTURA pantalones cargo

REFERENCIA PELO

Brillos ligeros en el pelo color blanquecino maybe algo azulado

Colores correas mochila etc

Colores botas

Textura botas

Clothes moodboard

Psychological Description

Raisen is patient and meticulous, liking to make sure that all her equipment is ordered and testing all her weapons to make sure they work, but once she sees an enemy she becomes aggressive and vicious, enjoying the fight and killing without remorse as she thinks is just the natural order of life. Due to conditioning during her training Raisen has great respect and fear to the higher ups of Weyland Corporation.

Her condition as a clone, the military and combat training she had and the lack of interactions with other people has made Raisen a person with difficulties when talking to people, being harsh and lacking empathy.

Walking / Mood

While Raisen is on the ship she walks with confidence, straight back and without haste, she likes to make things cautiously and make sure that everything is in order.

On the other hand, once she exits the USS Pandora and she knows there are enemies nearby she takes a more crouched position, with similarities to the position an alien takes when walking bipedal, with the torso inclined towards the front and the legs semiflexed. This alien-like behavior is even more exaggerated when her Predatory Rush ability is activated.



Predator Rush Walking/Mood reference

2.3.2 Antagonist(s)

Xenomorphs

The Alien species responsible for the slaughter of the workers of Weyland-Yutani on the planet. They are the principal enemies of our protagonist that we will need to kill to accomplish our objectives. The Xenomorphs are primal and savage, enjoying the act of the hunt, although they have enough intelligence to take tactics for hunting like ambushing, and solve puzzles (for references of their intelligence level, they are as intelligent ,or even more, as crows and octopuses).

Iscariot

As in almost every Alien film, there must be a robot that freaks out. In our case there are more than one, but this specific one is more **like David** (from Prometheus/Covenant), with awareness and creation ability. He is cold and scheming, he is in love with his creations (alien mutations), and will not stop studying them.

Iscariot, a discontinued model, gets to sneak in and modify the rest of the androids behavior and thinking, he is, basically, responsible for the Xenomorphs escape.

Physically is like any other robot, with some injuries from the aliens' acid, he is not violent or aggressive but he will defend his ideals, and his creations.

Preceding his love for his creations, **he always carries a species he created**, a a huge, thick lizard-like Alien, more like a snake, same head and anatomy from a Xenomorph, but without legs. This Alien has the name Jerry.

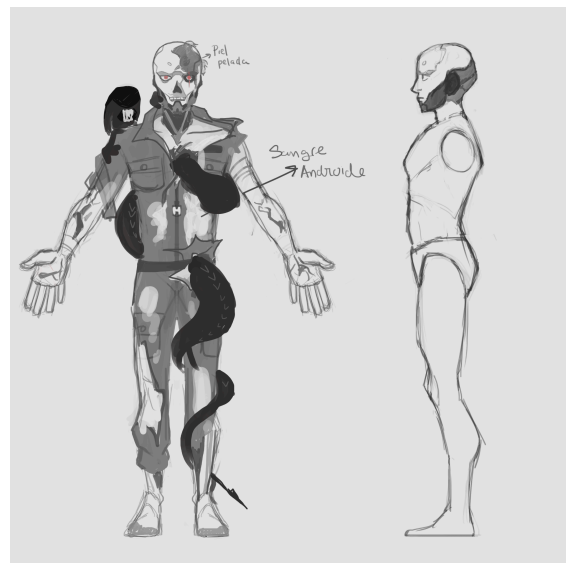

Iscariot concept art

Physical look:

Head: This character has the same head as any other android from the weyland-yutani company. However, an acid mark covers the top of his head, even slightly affecting the eye.

Iscariot, when his behavioral code is affected, his eyes glow bright red.

Body: A hole in his heart, and another in the right pelvis area, are pierced by his creature, which contours and moves around Iscariot's body as if it were its habitat.

On the exposed arms, small burns caused by the Alien's acid.

Clothes: Iscariot wears the company's corporate overalls. Sealed with a large logo on the back, covered and damaged, both by the holes and the creature.

The sleeves of the jumpsuit, completely torn leaving small strips of the material hanging down.

Overall, the overall is in poor condition, with burns, tears, holes and traces of various substances.

Mood: Iscariot is calm, has a quiet temperament and rarely gets upset, his functioning prevents him from doing so. The presence of the player bothers him but he does not allow himself to show it.

Animations:

•**Idle:** The character is standing still and stroking his pet, which is leaning over his right shoulder.

•**Anger:** The character leans strongly forward with fists clenched and staring straight ahead. His pet moves to his left side, also copying his master's character, stretching his neck and looking forward angrily.

Location: Iscariot can be found at the end of the game, just before the boss fight.

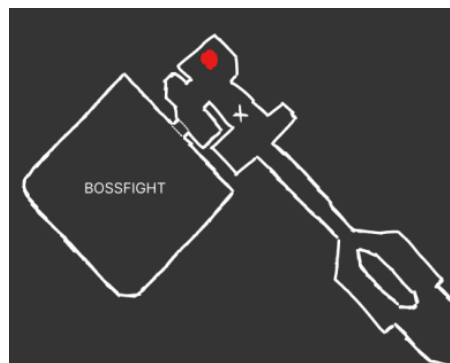

2.3.3 Supporting Characters

Caius

An android **located on the USS Pandora** to aid the main character with her mission. Is accountable for [upgrading the weapon](#) and [crafting new useful items](#) like grenades or chips after providing him the necessary materials.

Like any other android, Caius is created to serve, in his case, to serve the corporation.

This model is only available to senior corporate executives. He has no human traits but can synthesize a false empathy, as I said, he is created to serve, and if the owner needs to be told the owner is right, he will be right.

It cannot give advice, nor can it weigh itself, it can memorize and reprogram itself based on its owner's behavior.

His technical skills, on the other hand, has nothing to envy to any industrial machine, he is fast, precise, and can improvise weaponry with practically any material at his disposal.

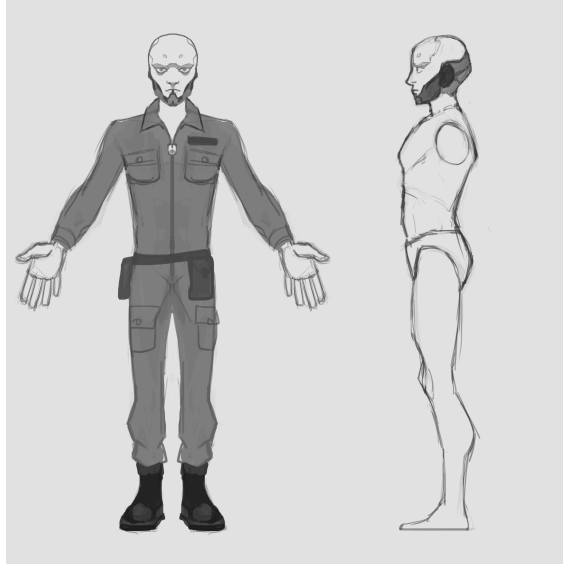

Caius concept art

Physical look:

Head: Perfect metal head, rounded, bald, with small details and indentations on the forehead and sides. Mandible, separated from the rest of the pieces, stands out for its darker color. Caius always keeps a serious character, he has no features that allow him expressiveness like humans. Her eyes light up in a ring of sky blue.

Body: Caius' body is mainly covered by overalls.

Following the aesthetics of his head, it is metallic with small details of different, slightly different plates.

His physiognomic structure follows healthy and normative standards.

Clothes: Caius wears the standard Weyland-Yutani corporate jumpsuit, in a striking orange color, with the giant logo on the back and, again, the same logo on the chest, in a darker color (gray, dark blue).

He takes care of his suit to the point of having it spotless, the colors are as saturated as the first day, and no print is minimally damaged.

Mood: He is friendly and caring, the closest thing to a robot butler.

Animations:

•**Idle:** It stands upright and waits for your requests. With his hands clasped behind his back and turning his head a few at a time he looks out over the ship.

•**Grooming:** Take your hands off his back to groom itself. He puts on his suit and dusts himself off. This animation would be interleaved with the Idle to avoid repetition.

2.4 Setting

2.4.1 Key Locations

GLS(gliese) 667

It is a rocky, uninhabited planet relatively close to Earth, about 23 light years away.

This planet is used as a cover to hide a series of unethical research, in which humans and androids are involved in search of new technologies and discoveries that could be beneficial to the Weyland-Yutani company.

It's a place where any colony could afford to set up, but in the end, the best hiding place is in plain sight.

However, in the face of any incident, action must be taken. The corporation cannot be allowed to be exposed, they may be the most powerful company in the known world, but even they stand to lose everything.



Gliese real life reference

Nova Era - LVL 1

Nova Era is the name given to this colonial factory. Located on the planet's surface, this warehouse serves as a cover, made to avoid attention, to avoid inspections, to divert the eyes from Gliese.

Full of high metal shelves with empty boxes, industrial tools and heavy machinery that is not used. A warehouse, full of lies.

Not far from this facility is the colonial town of the same name. This is where the colony in charge of the laboratory and their families live. This area will not be seen in the game.

Game Description:

An unused warehouse under the name of Weyland-Yutani corp.
It doesn't look like a dangerous place, it smells a bit burnt though.

The Hatchery - LVL 2/3

Just below Nova Era, The Hatchery. A laboratory where they breed Xenomorphs, and humans.

On the first floor of the facility, the most clinical, the most precise and the least dangerous work. Short corridors, operating rooms, different incubation chambers, all kinds of tools, and so on, distributed all over the place.

On the top floor however, we have longer corridors, spiraling pathways and much more open rooms. And in a safe and guarded place, the trapped Xenomorph queen and the different eggs she lays.

Game Description:

LVL2: There are no records of this place, although it looks like a research area. A laboratory? Under ground? As I said, no records available.

LVL3: If this was once a laboratory, it is definitely no longer one. All the walls, floors and furniture are covered in something black and slimy.

USS Pandora - Base

USS Sephora is the military vessel used in the game "Aliens: Colonial Marines".

This USS Pandora is a much smaller and more subtle vessel. Controlled by MU-TH-UR 6000 (an AI they call "mother"), this ship is loaded with hundreds of lifeless clones just like Raisen, Raisen herself and an android ready to assist the protagonist with any upgrades she can grant her.

Pandora will be a safe base for Raisen to board in order to store loot or talk to Caius for upgrade equipment.

Game Description:

A small ship from Weyland-Yutani corp. I've been on this one for decades, it's basically my home, and Caius is my brother. Quite a family.

2.4.2 World History and Lore

Working under the Alien IP, this entire story is set in and takes place within the film world of the Alien saga. With Prometheus, Covenant and Resurrection as the main reference points. Taking place after Covenant, around 2400.

Yutani, co-owner of Weyland-Yutani Corp, undertakes a secret project to extend her life, which takes place at The Hatchery.

The people in charge of this project have access to her DNA, which they work with to find possible mutations. In the meantime, Yutani awaits cryogenic storage on a corporate ship.

After the incident with Ripley in Alien 3, the scientists begin their experiments with the Xenomorph DNA, creating Ripley 8. In parallel, another group of scientists in charge of this secret project, follow the learnings of their colleagues and change the course of the research, having in their possession the Alien Queen from the planet Acheron (LV-426).

In these facilities they managed to create a chip-like implant that would help them with their mutational progress. This chip is able to store information about the individual from the moment he or she wears it (in the case of mutations, from birth). This information ranges from their behavior, to their memories, to their motor skills.

This information can be monitored, so that if a mutation is too aggressive, or has a disease, scientists would know without testing, and therefore be able to get rid of the unwanted subject in time.

However, they have not yet found a way to transfer this information between chips, so each chip is unique and non-transferable.

In The Hatchery, hundreds of synthesized human fetuses await their doses of Xenomorph DNA, or different variants created in that same lab.

When these fetuses are old enough, if they have no health problems, they continue their breeding, otherwise they are killed and incinerated.

The goal? to get the perfect DNA, the one that allows to regenerate wounds, cure diseases, extend life or even prevent death forever.

While this goal is not achieved, the most prepared subjects will be used as a weapon in possible confrontations (Raisen, our protagonist, is one of these subjects).

On the lowest floor, awaits the trapped and controlled queen laying eggs. The facehuggers are kept encapsulated until their use is required, and the more adult Xenomorphs die after use, some even before.

Once this impossible goal is achieved, a great mountain will bury these facilities, the colony will leave the planet, and Yutani will have what she craves most, eternal life.

Iscariot was a crew member of the USCSS Covenant as an assistant android. A poorly tested model similar to the new version of David, however, when Iscariot encounters the old version of David, he manages to convince our antagonist of his purpose, thus demonstrating both David's ability to convince and Iscariot's ability to be manipulated.

David doesn't trust this android and wants to continue his experiments in peace, so he sends the second one with an emergency capsule to spread his ideals to other androids.

Without expecting anything from this mission other than to lose sight of the subject, Iscariot manages to reach Gliese, where he manages to camouflage himself among the different androids for months in order to spread David's word among his own kind.

He finally succeeds, he gets them to believe him, to believe in his mission and his ideals.

A single Alien, a single one was enough to exterminate every human being in Nova Era and begin their own research for nothing but the benefit of the Xenomorphs, to bring them to life, to understand them, to study them.

2.4.3 Start setting

The player will start on the ship, where it will be introduced to the mission. Then, after the explanation, the player canTP to the tutorial and choose its weapon class.

This tutorial, as it will be separated to the rest of the levels, will be a one time thing (the player will only do the tutorial once).

2.5 Story milestones

Here the main events of the plot will be explained through, later on it will be specified what is told in each one, within the dialogue section, through the interactables and the NPCs.

–INTRODUCTION–

A cut scene introduces the player to the context necessary to start the game, then the player will appear in Caius' room.

Caius explains where you are and what your mission is in detail.

Then the tutorial starts, this is where the player learns that Raisen is a hybrid clone.

–STORY DEVELOPMENT–

LVL1:

TUTORIAL: A small part at the beginning of the level will be intended to introduce the player to the different mechanics of the game.

PART 1: In this part, the player begins to explore the place, discovering the state of the facilities (burnt areas, messy parts, corpses), as well as fighting the first enemies. In this part, the player should begin to understand his mission.

LVL2:

The player, gradually, discovers the “real deal” about the facilities (a lab where Xenomorph are being studied). They now should know that this is a cover with a lot behind it (illegal investigations, experiments, breeding).

LVL3:

PART 1: In this part information is simply added to strengthen the previous one.

BOSS: Before the combat, the player can talk to Iscariot. He will clear up any doubts the player may have about the facility, explain the origin of Raisen, the NPC's mission in the lab, and try to convince the protagonist not to kill the queen. **This dialogue is in the dialogue section under the name "THE END".**

–END–

Raisen goes back to the ship, and starts wondering about what she d.o, doubting her own existence, her actions towards the company. What should she do now?

Caius informs the corporation about this, the news is not in good taste, and they decide to eliminate any trace of the ship (they blow it up).

2.6 [Dialogues](#)

2.6.1 Dialogue types

Multiple choice: The player receives a text and can reply with multiple options (more than one). These dialogues will be used to interact with NPCs and at the Stations.



2.6.2 Dialogues guide

The dialogues will be introduced by the title from the character/characters that are talking. The first character will be the one starting the conversation. Following the header, within claudators, the type of dialogue that will be displaced.

Below the title, between parenthesis, there will be explained where and when the dialogue is shown in the game.





In red there will be a number, this number will be used as ID. The dialogues will be in a [Drive folder](#), as a name they will have this ID.



In order to read the dialogues, just download the desired dialogue and run the file.







Dialogue display example 

CAIUS - RAISEN [multiple_choice] [001]

(USS pandora. The player has gone thow one run and talks to caius.)

Compartit amb mi > PROJ III - ALIEN > 3. DESIGN > Dialogues    

Típus  Persones  Modificació 

Nom 	Propietari	Darrera modi... 	Mida del fitx 
 001.html 	 jo	11:46	465 kB 

Oh, good, I see they've woken you up. Just in time.

In time for what?

Woken me up? What do you mean?

Up and ready for the mission.

2.6.3 Dialogue Wireframe

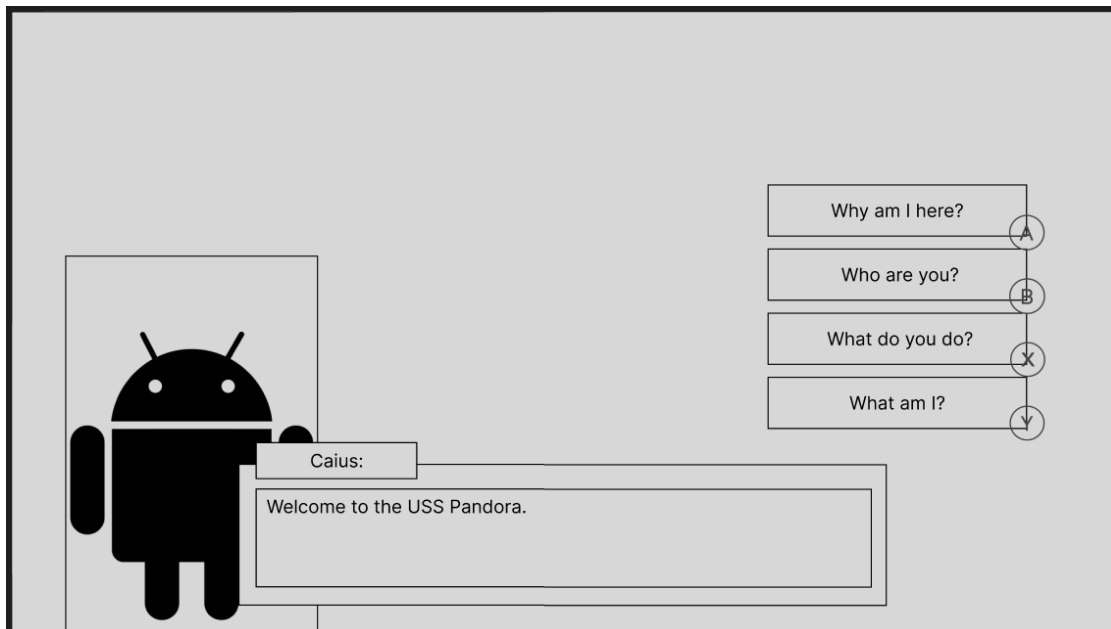

Wireframe of the dialogue system

There will be a maximum of 4 text options; if there are fewer, only the necessary ones will appear. If there are none, only one option will appear with '...'

2.6.4 Game Dialogues

DIALOGUES

–GAME INTRODUCTION–

CAIUS - RAISEN [multiple_choice] [001] DONE

(USS pandora. The first time the player enters the game, the player won't be able to continue unless they talk to the NPC. This dialogue will be displayed once.)

–STATIONS–

CAIUS - RAISEN [Multiple choice] [006] DONE

(USS pandora. The player has interacted with the broken holo screen in lvl 1, dialogue id:100.)

This option will appear, to start the conversation:

Raisen: I found some data.

CAIUS - RAISEN [Multiple choice] [007] DONE

(USS pandora. The player has died for the first time.)

This option will appear, to start the conversation:

Raisen: Can't I die?

CAIUS - RAISEN [Multiple choice] [008] DONE

(USS pandora. The player has interacted with the head in lvl 1, dialogue id:102.)

This option will appear, to start the conversation:

Raisen: Ask about the head.

CAIUS - RAISEN [skipping] [009] DONE

(USS pandora. The player has played lvl 1)

This option will appear, to start the conversation:

Raisen: The Xenomorphs, they look familiar.

CAIUS - RAISEN [Multiple choice] [010] DONE

(USS pandora. The player overpass lvl 1 and unlocks lvl 2)

This option will appear, to start the conversation:

Raisen: This place is more than a warehouse, right?

CAIUS - RAISEN [Multiple choice] [011] DONE

(USS pandora. The player overpass lvl 2 and unlocks lvl 3)

This option will appear, to start the conversation:

Raisen: The lab, is that a nest?

CAIUS - RAISEN [Multiple choice] [012] DONE

*(USS pandora. The player interacted with the corpse in lvl 3, **dialogue id:106, AND HAS NOT FOUGHT WITH THE FINAL BOSS**)*

This option will appear, to start the conversation:

Raisen: Empress.

–INTERACTIONS–

LVL1:

PART 1:

HOLO_SCREEN- RAISEN [skipping] [100] DONE

(Mid vl1, the holo screen is before entering the corridor to get the star. The player finds the object on the floor and interacts with it)

CORPSE- RAISEN [skipping] [101] DONE

(Start of lvl1, the corpse is holding the key. The player finds the corpse laid in a corner and interacts with it)

ANDROID_HEAD- RAISEN [skipping] [102] DONE

(End of lvl1, the head just before crossing the exit doorway threshold. The player finds the head on the floor and interacts with it)

LVL2:

PART 1:

CORPSE- RAISEN [skipping] [103] DONE

(Start of lvl2 part1, just before the hidden “star”. The player finds the corpse laid in a corner and interacts with it)

TABLET $\frac{1}{2}$ - RAISEN [skipping] [104] DONE

(End of lvl2 part 1, elevator room. The player finds an artifact on a table and interacts with it)

PART 2:

TABLET $\frac{2}{2}$ - RAISEN [skipping] [105] DONE

(Start of lvl2 part 2, elevator room. The player finds an artifact on a table and interacts with it)

LVL3:

PART 1:

CORPSE- RAISEN [skipping] [106] DONE

(Start of lvl3 part1, just after the door The player finds the corpse lying in the middle of the right wall and interacts with it)

C4- RAISEN [skipping] [107] DONE

(Mid lvl3 part1, where the red key is and the player interacts with it)

CLOTHES- RAISEN [skipping] [108] DONE

(Mid lvl3 part1, a pile of clothes underneath there is a key and the player interacts with it)

ANDROID_BODY- RAISEN [skipping] [109] DONE

(End of lvl3 part1, just next to Iscariot.)

-THE END-

ISCARIOT- RAISEN [multiple_choice] [198] DONE

(End lvl3 part1. Just before entering the boss fight. **This IS NOT a compulsory dialogue.** Once the player kills the boss, the dialogue **WILL NOT BE ENABLED, AND ISCARIOT WILL DISAPPEAR.**)

RAISEN- RAISEN [skipping] [200]

(End, back on the ship. The player has overpassed the mission, and now Raisen thinks about what really happened. This dialogue only displays **if the player knows their origins.** **THIS IS THE LAST DIALOGUE**)

2.7 CutScenes



3. Gameplay

3.1 Core Gameplay Loop

Raid → Farm monsters and explore → [Base and upgrade character](#) → Raid.

This is the main game loop until the player reaches the final boss in a raid and finishes the game. It is a playable loop similar to *Diablo* and *Zero Sievert*. In *Diablo* the base would be the town where the player manages the inventory by selling and obtaining new items.

3.2 Core Mechanics and Features

Some of the next mechanics are better explained in the other following sections.

Camera

Top-down isometric, just like *Diablo IV* but even a bit further than the example below.



Diablo IV gameplay

On Unity, the camera values are the next ones:

camera position = Vector3(-75, 100, -75)

camera rotation = Vector3(45,45,0)

```

UnityScript (2 asset references) | 0 references
public class CameraMovement : MonoBehaviour
{
    //player
    [SerializeField] GameObject target;

    //position difference between camera and player
    [SerializeField] Vector3 diffPos; //-75, 100, -75

    //camera velocity
    float followStrength;

    bool follow, stopped;

    Vector3 lastPosition;

    public float wait; //Valor es 0.5f
    float time;
    float interpolationTime;

    @ Unity Message | 0 references
    private void Start()
    {
        //The camera velocity is equal to the players
        followStrength = target.GetComponent<MovementPlayer>().velocidad;
        lastPosition = target.transform.position;
        follow = false;
        stopped = true;
    }

    // Update is called once per frame
    @ Unity Message | 0 references
    void LateUpdate()
    {
        time += Time.deltaTime;
        if(lastPosition == target.transform.position)
        {
            if(!stopped) { time = 0.0f; } stopped = true;
            if(time > wait)
            {
                follow = false;
                time = 0; interpolationTime = 0;
            }
        }
        else
        {
            if(stopped) { time = 0.0f; } stopped = false;
            if(time > wait/5)
            {
                follow = true; time = 0;
            }
        }

        if (follow)
        {
            Vector3 newPos = lastPosition + diffPos; //Siempre va un frame por detras del player para dar un pequeño retraso y mayor sensación de movimiento

            float dis = Vector3.Distance(transform.position, newPos);
            interpolationTime += Time.deltaTime/ 2; //2 segundos
            transform.position = Vector3.Lerp(transform.position, newPos, Mathf.Min(interpolationTime, 1.0f));

            lastPosition = target.transform.position; //Posición del player para ir con un cierto delay
        }
    }
}

```

In our engine, the camera transform will be as such:

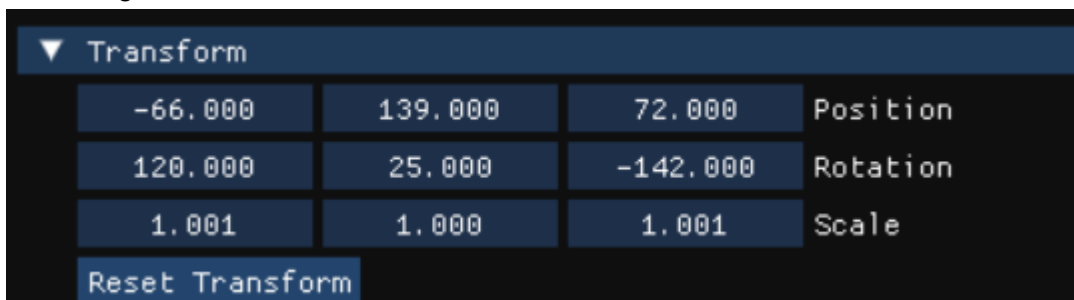

The features of the camera are the next:

- The camera will follow the player with some sway/delay/lag. If the player has been still for more than 0.5 seconds and then moves the camera will wait 0.1 seconds to follow the player and will make a lerp of 2 seconds before becoming completely centered on the player again. After that if the player keeps moving it will follow him smoothly until it becomes still for 0.5 seconds again. The camera will be always a game frame behind the actual position of the player.

- If the player is behind a wall an aura/shader of color green similar to the one of the [UI](#) will be shown through the wall to be able to know the position of the player



Reference from Diablo IV

- When pointing with some throwable utility the camera should move towards the position the player is aiming. Always being within the range of the camera, close to the center according to the rule of thirds. The position is approximately the midpoint between the thirds division of the screen and the center position where the player normally is.

The idea of this subtle change is to not disorient the player when moving the camera in the middle of combat.

In **Unity** this distance is adding the forward of the player 20 times to the position the camera looks at.

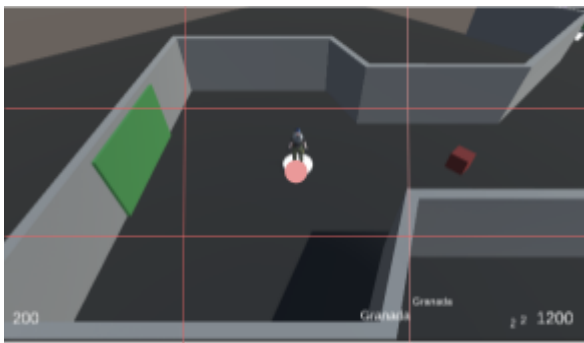

Normal camera position



Displaced camera position

Other features

The player would have a point light emitting from its backpack shining to increase the visibility on the darker areas of the game. This light would be of a yellowish coloration, having an RGB value of (255,255,175).

During the [boss fight](#), the camera should change to match the orientation of the boss room. The camera would switch to a top down view.

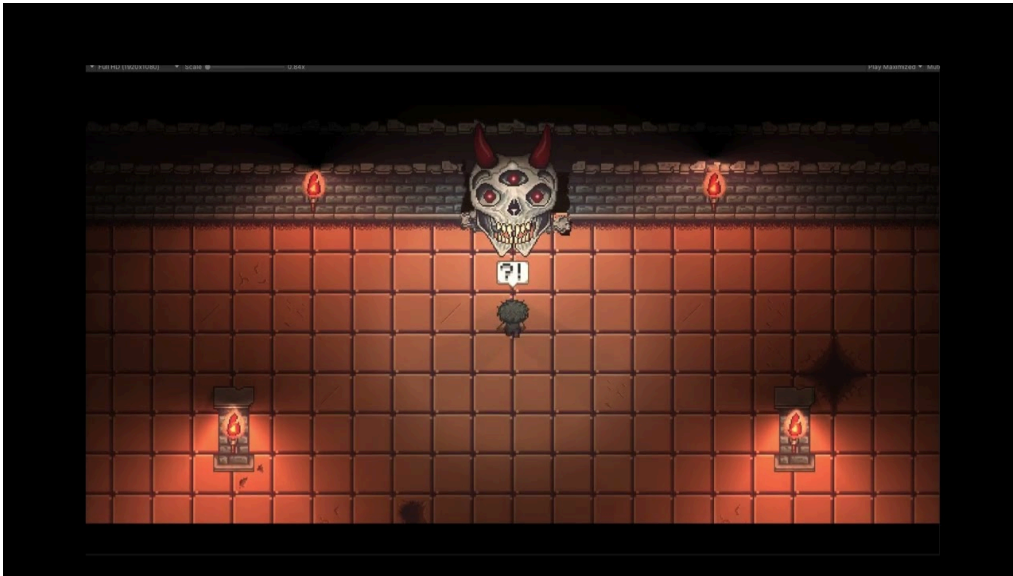

Reference image

Base Teleporter

- The base teleporter allows the player to go to raid from the base
- Once the player interacts with the teleporter in base a [menu](#) will pop up where the player has to choose a level and a weapon only then the “go to raid” button will activate and if it’s pressed the player will TP from base to the lvl he selected.
- The selectable levels will only be unlocked if the player has already gone through that lvl (so if the player completes the lvl 2 and goes to the lvl 3, the lvl 2 will be unlocked on the base teleporter).
- Level 1 will be unlocked from the beginning.

Extraction Teleporter

- The extraction teleporter is the player's way to get out of a raid by teleporting to base. This would be represented in the form of a beacon or similar.
- The player will always have at his disposal where this extraction point (TP to base) is, it will be on the map.
- Depending on the level, there will be different placed extraction teleporters.
- Each level has two parts, the extraction point will always appear in the second part, meaning at the end of the level or before the next one starts.

- As the extraction beacon will be close to a hostile area, it will have a 2 unit radius area. While the player is inside this area, a counter will start counting down (depending on the floor: LVL 1 - 4 secs. LVL 2 - 6 secs. LVL 3 - 8 secs), when it reaches 0, the player will teleport to the base. The player will be able to move, shoot and use abilities and consumables while waiting and defending against enemies.

Weapons

- In the game, the player has 3 classes at his disposal, these are represented by weapon types ([submachine gun](#), [shotgun](#), [plasma](#)).
- The player will be able to choose which weapon to use when transporting from the base to the planet (any level), through a [menu](#).
- Each weapon has a skill tree of up to 3 upgrades. The last one is divided into two upgrades of which, the player will have to choose which one he wants. These upgrades are available at the weapon upgrade station. The material used to upgrade a weapon is the "Alien Core", each upgrade has different costs.

Items

- The game has a total of 14 items, 7 of which are obtained through enemy drops, 1 is a unique material that only comes out of chests, and the rest are craftable (equipable, utility) items.
- Materials dropped by enemies (except resin) are used to craft other items in the crafting station managed by Caius, the assistance android on board Pandora.
- Craftable items are divided into two groups:
 - Utility (Grenade, baker house)
 - Equipables (Armor, defensive chip, offensive chip)
- Each item has three possible rarities: common, rare, epic. Depending on the rarity, this item will be stronger or weaker.
- Each level has two chests, one hidden and one protected.
- These chests reset after run and do not disappear between them, i.e. if you open a chest and return to base, when you go back down the chest can be opened again.

Altar

- On the levels there are altars, statues of an alien that's holding an Alien Core, the item used to upgrade the weapon

- The statue and the item will spawn on entering the raid

Equipment

- All equipable items have a recipe, this recipe tells the items needed to craft an equipable item.
- All equipables are made to improve the [player's stats](#).
- The rarity of the equipable item will be affected by the rarity of the materials the player use, through percentages, i.e. if in a recipe the player have 3 materials of rarity COMMON, RARE, EPIC, there is a chance that the equipable will be of any of the 3 rarities, however, it is much more likely to be RARE as it is the middle ground.
- The player will have 3 slots in the inventory to equip different items. 1 slot for armor and 2 slots for chips.

Crafting

- The player can collect materials in raid and use them to craft useful items such as better armor, or powerful consumables like grenades.
- All the crafts exist within a recipe. These recipes contain X materials (depending on the object to craft).
- To craft the items the player has to go to the crafting station (Caius) in the base.

Item management

- In raid the player will pick up the items automatically if there's a free slot in the inventory.
- Inside the [inventory](#) the player can manage the items: moving them inside the grid, equipping them (if equipable) and throwing them in the ground.
- In the base the player has a big stash where he can store items so they are not lost if he dies in a raid.

Movement system

- The player will be able to move in all directions
- There's a [dash](#), a skill with a cooldown that allows the player to dodge attacks and enemies as well as getting close/far quickly.

Combat system

- In raid the player will confront the [enemies](#): aliens
- The player can use the [weapon](#) he chose on entering the raid to shoot the enemies, this weapon will have infinite ammo but a reload will be needed when out of bullets.
- He can also make use of the [3 skills](#) to damage the aliens and use the consumables.
- When shooting and using skills the player will do it to the closest enemy.
- The consumables are aimable by the player.
- All the character combat will be ranged or AoE.
- When attacking, the player will always stay still.
- There's 3 types of enemies with different behaviors and abilities.

Extraction

- In raid, the player will have two options: Go to the next level or extract.
- The extraction will work as the tp mentioned earlier.
- When extracting, the player goes to base and conserves all the items and equipment.

Death

- The player can be defeated by the enemies when his HP reaches 0
- When dying, all the loot in the inventory and equipment is lost, except the item located in the "Safe Slot" in the [inventory](#).
- The weapon upgrades don't get reseted when dying.
- Once dead, the player respawns on the ship with the item in the safe slot on the inventory (if there's one).

Heals

- Healing is indispensable for the player. It will allow the player to [heal](#) at any time.
- **Heals are not consumables.**
- The player will start with 2 "healing containers", called Resin Vessels.

- When using a Resin Vessels, the content is lost but not the vessel, if the player finds resin on the ground, it will be automatically refilled if it is empty.
- The vessels can be crafted in such a way that up to 8 heals can be accommodated.
- Whenever the player is on the ship it will automatically heal and refill all the healing vials.
- Heals cannot be moved or managed from the inventory, they have a specific slot in the HUD and cannot be moved from there or selected in any way. Basically the Resin Vessels are not items, and when crafted a Resin Vessel is added on the HUD.

Save/Load

- The game will save when interacting with “the mother” in the base and when the player enters any level.
- The save functionality will save the stats of the player, the level he’s in, items in the inventory, equipped items, items in the stash, number of total resin vessels (potions), weapon upgrades, unlocked levels, doors opened and if the player has spoken with Iscariot (since it defines the ending)
- The game will load the last saved file when the “play” button is selected. On load the character will spawn at the start of the level where the last save was made (In the base it will spawn near the mother)

In-game pause

- The player can use the Start Button to pause the game and access the menu.
- Everything in the game will stop and a menu will appear showing three options: Continue, Main menu and Exit game

3.3 Stats and Characteristics

Health

This statistic represents the subject endurance, in case of enemies, this statistic divided among percentages (50%, 25%, 10%) can be used for different enemies behavior.

When health is down to 0 or less, the subject dies.

Our player will start with 1200 HP and this won’t change throughout the game.

Each time the player loses health, particles of splashes of blood will appear. These particles will originate from the center of the player in all directions, slightly upward, and then rapidly fall as if they had gravity.



Reference 1: https://www.youtube.com/watch?v=-zADcvB2bvE&ab_channel=skunkmunkee

Reference 2: https://youtu.be/IQkLtr63_cM?si=IHgO-M0HjJGAIIntU&t=11 (or maybe smoke, considering the distance, it might not be seen)

Armor

This is a static number that can be changed with objects (armor, consumables). This number acts as a filter for the damage before acting on the health. This number is a normalized percentage between 0-1, 0 being no resistance at all, and 1 being no receiving damage. In our game this number will never rise above 0,5.

Total DMG = DMG * (1-Armor)

Base damage

This is the pure number for damage, set by the weapons or abilities in the player's case, or by base stat for the enemies.

For the player, this number will be multiplied by the "damage multiplier", that will be the damage to apply for the formula above.

Damage multiplier

As the Armor, the damage multiplier will be used as an intermediary for the (in this case), the damage.

This number will start at 1 (character "lvl 1" with no items), so the base damage match with the dealt (DMG = 10; DMGM = 1; DMG * DMGM = 10). This number will rise and be modified with items. Depending on the item, this number can become a scale between two numbers, the one used will be a random between the lowest and the highest.

For this to happen, the stat must have two variables (as an array or as two separated floats), in case it is the same number no random will be applied.

Damage multiplier only affect skills damage.

Speed

The speed determines how fast the character or the enemies move. There are various elements that can change the speed temporarily like character skills.

3.4 Character Mechanics and Controls

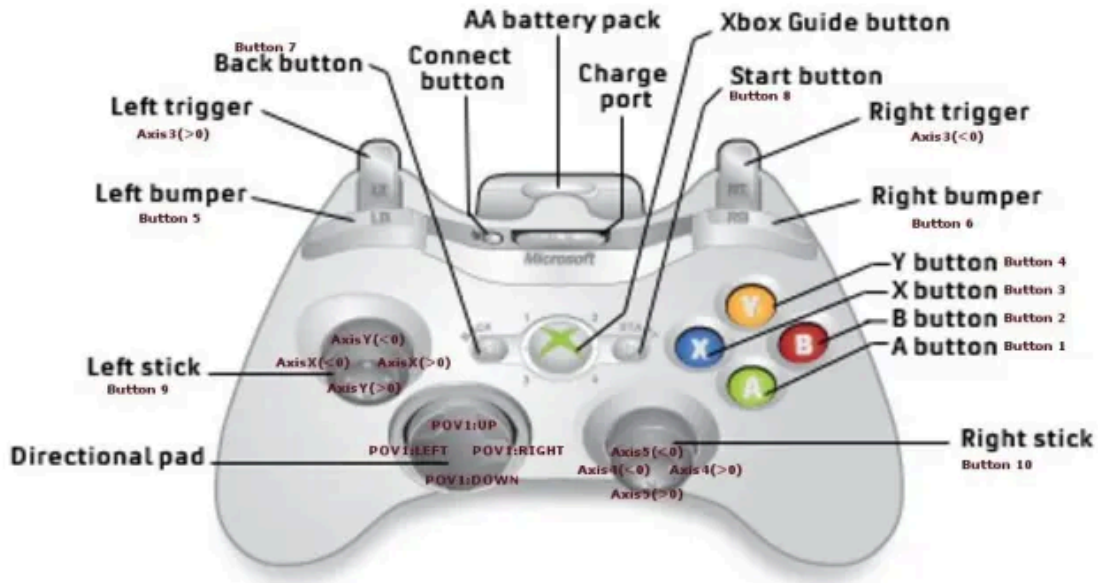

Controller atlas

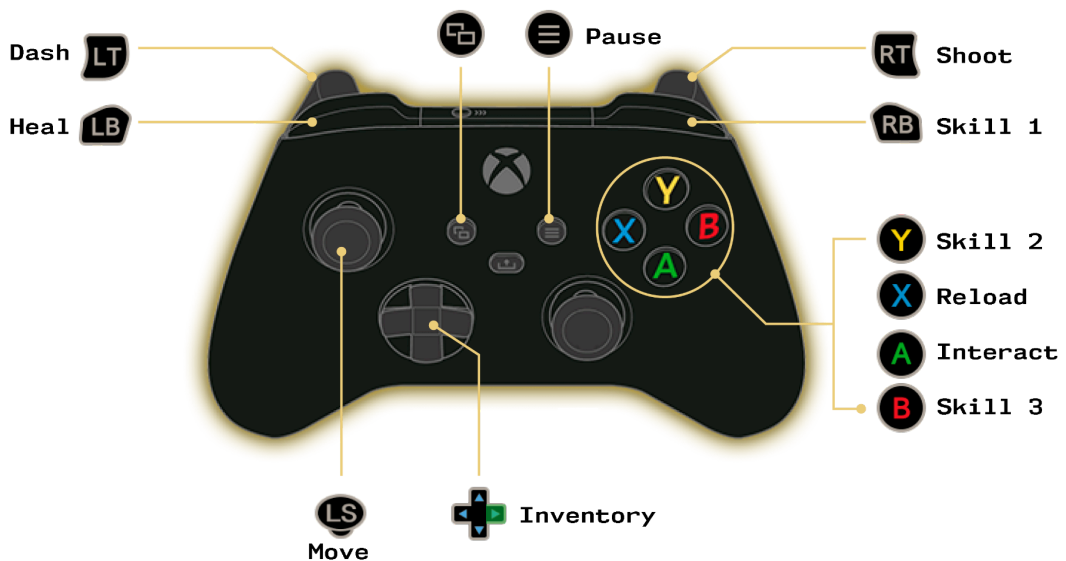

Running

Main moving mechanic.

Controls:

- Controller: Left stick
- Keyboard: WASD

Rotation: 360°

Velocity: v

Interact

- The player can interact with some things in the game.
- The player can only use this function if he can interact with something.

Controls:

- **Controller:** A button
- **Keyboard:** E

Map

- The player can open the map to see his location and other points of interest.

Controls:

- Open Map
 - **Controller:** Directional pad: Up
 - **Keyboard:** M
- Close Map
 - **Controller:** Directional pad: Up / B button
 - **Keyboard:** M / Esc

Inventory

- The player can open the inventory to manage the items.

Controls:

- Open the inventory
 - **Controller:** Directional pad: Right
 - **Keyboard:** Tab
- Close the inventory
 - **Controller:** Directional pad: B button
 - **Keyboard:** Tab / Esc

(To see the controls to manage the inventory go to [3.5 - Inventory and Equipment](#))

Dash

- The player dashes at the direction he's looking/going, this is done by augmenting the moving velocity by 4 times during 0.25 seconds.
- While dashing the player becomes invulnerable during the full duration of the dash, the projectiles go through him and do not collide with enemy hitboxes.
- While the player is dashing, the UI will show the dash icon with a reduced gamma.
- When the dash is finished, the cooldown starts.
- While dashing, if the player collides with a rigid object, the dash is canceled ahead of its finishing time and the cooldown starts.
- While the player is dashing, he can't do anything else.

- If the player finishes the dash inside an enemy hitbox, the player will move just outside the hitbox and take the pertinent damage.
- While on cooldown (it will be shown in the HUD) the player cannot dash and if he tries a sound will be played.
- While Dashing, the player will create a particle trail behind her during the dash to represent the fast movement. These particles will be white stripes with a low alpha component, with its ends finished on a spike.



Example Image, although there should be more lines and of less length

Reference: <https://youtu.be/QyqSoz2ivOk?si=3Wpeb9fmdwN7lvC6&t=811> (in our game they would go like a trail not in front of the player).

Controls:

- **Controller:** Left Trigger
- **Keyboard:** Spacebar

Velocity: $4 * v$

Duration: 0.25s

Cooldown: 3.5s

Basic attack

- The character will shoot the closest enemy.
- If there's no enemy on the screen, the character will shoot in the direction he's looking at.
- While shooting the player will **stay still** and look at the direction of the enemy he's shooting at.

- The shooting mechanic will change depending on which [weapon](#) was chosen by the player at the start of the raid, but all of these mentioned characteristics are the same for all three of them.

- Shooting will generate sound and particles depending on the [weapon](#).

Controls:

- **Controller:** Right trigger
- **Keyboard:** Mouse left-click

Reloading

- The character can reload the main weapon and the reloading time varies in each weapon.

- The reload gives the player the maximum amount of bullets (this amount changes depending on each weapon).

- The bullets are replenished when the reload time finishes, not when the character starts reloading. The reload time varies depending on the weapon.

- The character **reloads automatically** when it's **out of bullets** or if it's **been 2 seconds** since the **last shooting** input.

- If the character is **reloading** and the player uses the shooting input, the reloading **will stop instantaneously** and will start shooting.

- While reloading, If the weapon has 0 bullets, even if the player presses the shoot button, the reload will not stop and the 2 seconds mentioned earlier will not reset.

- If the player **uses any ability (including the dash) while reloading** it stops reloading and when that action is finished it starts reloading again.

Consumable

- There's two slots in the player's equipment where he can place a consumable.

- In raid the player can use the "Down Pad" button to swap between the both equipped consumables.

- In raid the player can use the selected consumable.

- The player can hold the consumable button, and select in which direction will be used, once the player stops holding the button, the consumable is thrown to the selected direction.

- If the player does not hold the button and only presses it, the consumable will be thrown in the direction he's looking at.

Controls:

Use consumable:

- **Controller:** Right bumper
- **Keyboard:** Mouse right-click

Swap consumable:

- **Controller:** Directional pad: Down
- **Keyboard:** Mouse right-click

Healing

- The player can use the [resin vessel](#) to instantly heal a portion of the HP. This portion depends on the "Healing Efficiency" stat, being a base of 33% of Maximum HP (400 HP) with 0% of healing efficiency. The healing efficiency stats is an % increase, so a 30% of healing efficiency would increase the healing by x1,30.

- The character can move while healing and there will be no animation since it's an instant process.

- When the heal is used, a cross typically associated with healing (+) particles appear from the center of the character moving upwards and in random direction horizontally accompanied by a glow. All of this in a very bright green tone to differentiate from the acid.

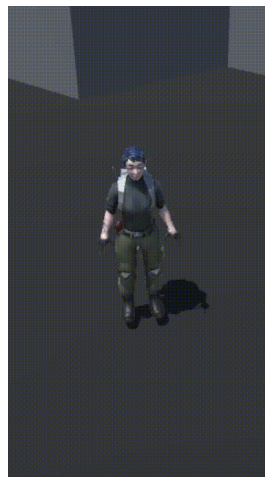

Controls:

- **Controller:** Left Bumper
- **Keyboard:** Q key

3.4.1 Skills

Skill 1: Acidic spit

- The player shoots a spit of acid in a medium range against the nearest visible enemy that explodes in a small area after impacting with an obstacle or enemy. If it hits an enemy it deals 90 damage to the hit enemy and then deals 25 damage in a small area to all enemies including the first, dealing a total of 115 damage.
- If there is no enemy nearby the player will shoot in a straight line where it is looking as if it was shooting with a weapon.
- After the explosion the spit leaves a small puddle of acid that lasts 1.8 seconds and slows down enemies that enter inside and don't leave by a considerable amount (40% of speed reduction) and deals 25 extra damage to enemies standing over the acid each 0.3 seconds, doing a total of 150 damage over time. Adding the initial hit damage the skill deals a total of $90 + 25 + 150$ the skill has a potential damage to only one enemy of 265.
- The maximum range of the spit is 15 times the radius of the player hitbox while the radius of the explosion and slowing puddle is 4 times the player hitbox (6 meters in Unity).Frames
- The attack has a preparation time of 0.2 seconds (10-14 frames assuming 60 FPS) , an execution time of 0.3 (15-18 frames assuming 60 FPS) and a recovery time of 0.2 (10-14 frames assuming 60 FPS) having a total duration of 0.7 seconds (between 35 and 46 frames assuming 60 FPS)
- The spit projectile itself is covered in green particles that leave a trail that descends to the ground until despawning. Once it hits and creates the acid puddle the acid itself would emit small and very transparent smoke particles to represent that it's "eating" the ground due to the acidness.



Example of acid color and puddle. It would have a slightly different coloration to differentiate from the acid puddle of the enemies.

Cooldown: 7 seconds

Controls:

- **Controller:** R1 button
- **Keyboard:** 1

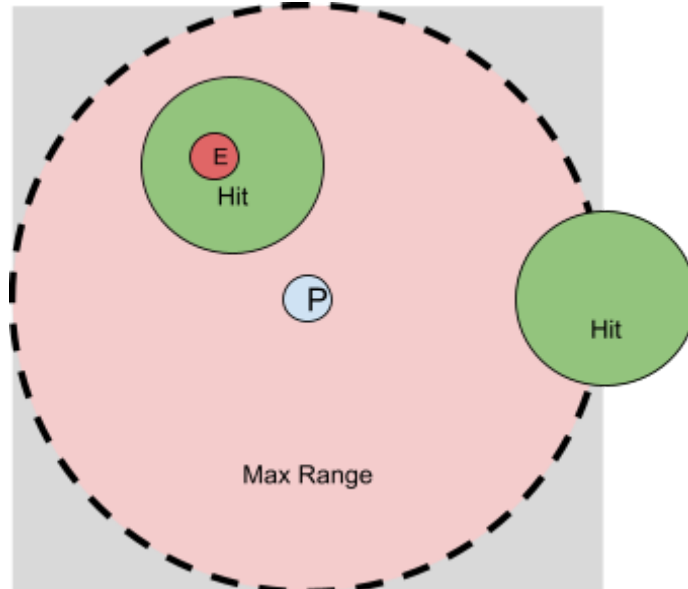

Skill 2: Predatory Rush

- The character enters an adrenaline rush using its alien physiology, increasing its stats.
- The movement speed is increased by 150% (the speed is multiplied by x 1.5), armor is increased by 30% (x1,3 increase), weapon cadency is augmented by 30% (the time needed to shoot is multiplied by x0.7) and weapon reloading time is decreased by 50% (it takes half the time to reload) while dash cooldown is reduced by a 50% (instead of being every 3.5 seconds it would be every 1.7 seconds).
- The adrenaline rush lasts for 6 seconds.

Cooldown: 22 seconds once the adrenaline rush ends. Each time the player kills an enemy the cooldown is reduced by 0.2 seconds.

Controls:

- **Controller:** Y button
- **Keyboard:** 2

Skill 3: Tail Swipe

- The Character makes a swipe with its tail on a 360° attack, dealing 80 damage and pushing all enemies within the area to the outside of the area.
- The attack has a small area, being approximately 4 times bigger than the circumference containing the character hitbox.

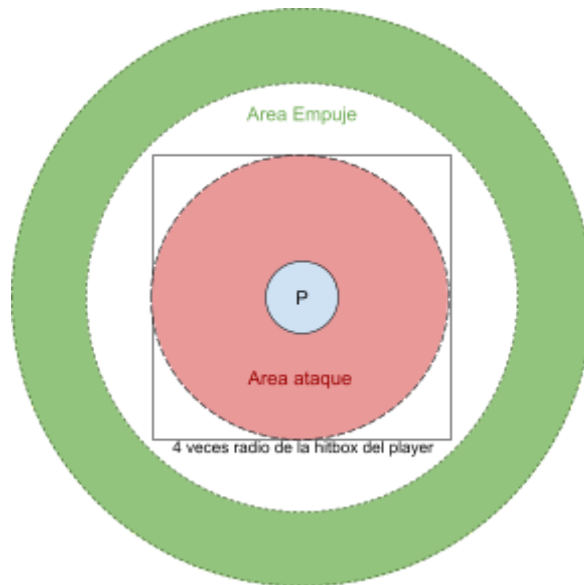

- All enemies are pushed to the outside range of the area after being hit by the attack. The farther away from the center of the area the enemies are the less they are pushed. The distance pushed is equal to:

$$\text{PushedDistance} = ((100 - (8 * \text{DistanceEnemy} + 0,7 * \text{DistanceEnemy}^2)) / 100) * \text{MaxRadius}$$
 (10 and 1,5 are the parameters that determine how much knockback the skill has. The first one determines how near in general are the enemies thrown, the higher the parameter the more near they are sent, while the second scales more the farthest away the enemy is)

- The attack has a preparation time of 0.3 seconds (15-18 frames assuming 60 FPS) , an execution time of 0.35 (21-24 frames assuming 60 FPS) and a recovery time of 0.1 (4-8 frames assuming 60 FPS) having a total duration of 0.7-0.8 seconds (between 40 and 50 frames assuming 60 FPS)

-During the spin the tail would emit a trail of particles similar to the ones of the dash to represent speed.

Cooldown: 13 seconds

Controls:

- **Controller:** B button
- **Keyboard:** 3

3.5 Inventory and Equipment

The player can use the [inventory](#) to manage items. The inventory consists in two parts: The item slots, where the items looted by the player will be stored, and the Equipment, where the equipable items are placed. **The items are not stackable.**

- The player can move **between the equipment and the item slots using the Left Stick to move between items.**

3.5.1 Item Slots

- It has **5 rows with 3 slots each.**
- When the player **picks an item from the floor**, it will be placed on the **first empty slot.**
- **There's an extra slot below the inventory called Safe Slot** and if the **player dies** the item in that spot does **not get lost** and the player **respawns with that item** in the same spot in the inventory.
- **All the items occupy the same amount of slots.**
- When the player **opens the inventory**, the **first** item slot will be **hovered.**
- **While** an item is being **hovered and the right bumper button is held down**, its **information** is shown.
- The player can **change the hovered item** in the 3*5 grid by moving the **Left Stick** in the four directions.
- **When hovering** an item the controls are:
 - **“A button”** to select and **hold the hovered item (not holding in game, just in the inventory)**, once the item is holded the slot becomes empty and the item is shown with a hand holding it in a reduced size on the top-right of the hovering square. While the item is being holded the player can continue to hover items and move through the grid.
To place the selected item to a desired position the player has to press the **“A button” again**, if there's another item where the holded item is going to be placed, the item on the occupied slot becomes the one selected and the holded item is placed.
Since even if the player is holding an item, the other ones can still be hovered, the hovered items information is also shown and he can interact with them as if no item was being holded (this more or less works like the PC in pokemon).
If the player closes the inventory while holding an item, the item will be placed on the first empty slot of the inventory.

- **X button to equip** the hovered item, if there's an item equipped in the same place the player is trying to equip it, the position of the two items swap, so the equipped item goes to the item slot and the item in the slot goes to the equipment slot (for example, if an armor is equipped and the player hovers over an armor in the inventory and uses the X button, the equipped armor and the one hovered swap places).
- **X button** to move the hovered item to the first empty place of the item slots **in the base stash** (if there's no empty slots nothing will happen and a sound will be played).
- **Left bumper to throw** the hovered item on **the floor in a raid** (if it's throwable).

3.5.2 Equipment

- **The equipment consists of an armor slot, two chip slots and two consumable slots.**
- When hovering an **equipped item** there will be these controls:
 - **A button** to hold the item and it will work **as the item slots**. **If a non equipable item is tried to be placed in an equipment slot nothing will happen** and a sound will be played.
 - **X button to unequip** the item, the item will go to the first empty slot of the inventory if there's one. If there are no empty slots the item will not be unequipped.
 - **Left bumper to throw the hovered item** on the **floor** in a raid (if it's throwable).
 - The player can change the hovered item by moving the Left Stick in the four directions.
 - **Y button** to move the hovered item to the first empty place of the item slots in the base stash (if there's no empty slots nothing will happen and a sound will be played).

3.6 Items and Crafts

3.6.1 Drops

There will be 7 **drops**. When dropped, an item will one of **three rarities** will change it's spawn chance **depending on which level is the player in**:

- LVL 1: **Common**: 60%, **Rare** 25%, **Epic** 15%
- LVL 2: **Common**: 20%, **Rare** 50%, **Epic** 30%
- LVL 3: **Common**: 10%, **Rare** 30%, **Epic** 60%

These items are dropped on the floor by the enemies when killed and picked up by the player automatically unless it has the inventory full. When an enemy dies, it has its own "drop rate" that indicates if an item will be dropped. If there's a drop, the next step is to calculate the rarity of it following the previous mentioned %. Finally an item from the alien loot pool is randomly selected (depending on the enemy each item has different %).

- **Alien Resin:**
 - **Description:** The resin is secreted by the xenomorphs' jaws. They have a viscous texture and a deep black color. They use this material to build their nests, which hardens in direct contact with air.
 - **Functionality:** This item has **no rarity** and it does not work like the other items. The resin is basically the **healing**, when the player picks it up he fills up one **resin vessel**. If the player has all the vessels full the player won't be able to pick it up and it will remain on the floor.
- **Alien Skin:**
 - **Description:** These are made of a tough material, capable of resisting the creatures' own acid. Varies in color according to the species and age of the creature.
 - **Functionality:** Most common drop, used in multiple crafts.
- **Alien Claw:**
 - **Description:** Shiny, black and extremely sharp claw, capable of slicing through almost anything within its grasp.
 - **Functionality:** Used for making the baker house and the offensive chip.
- **Alien Tail tip:**
 - **Description:** A segmented, razor-tipped tails, a strong cutting weapon. It can lift people off the ground without any effort.
 - **Functionality:** Used for making the baker house.
- **Alien Acid Vesicle:**

- **Description:** Acid-filled organic bags, varying in size and shape depending on the species of xenomorph.
- **Functionality:** Used for making the grenade.

- **Alien Exocranium:**
 - **Description:** An elongated shell resembling a banana. Hard, resistant and light. Sometimes containing some vesicles on the sides.
 - **Functionality:** Used for making the armor and the defensive chip.

- **Alien Aluminum bone:**
 - **Description:** These bones are not made of aluminum, although their color, appearance and properties may be reminiscent of aluminum. It is light, soft, malleable, and a good conductor of both electricity and heat.
 - **Functionality:** Used for making chips.

3.6.2 Crafts

The crafted items will have a rarity according to the items they've been crafted with, and the **craftable items** are:

- **Armor:**
 - **Description:** An exo-armor that will help you withstand the blows of Xenomorphs. It's light and tough, much better than marine tech.

 - **Functionality:** Equipable item that gives the player a certain **amount of armor** depending on rarity:
 - **Common:**
 - **Rare:**
 - **Epic:**

- **Baker house:**
 - **Description:** Legend says that this house belonged to a mysterious entity with the powers to prevent memory leaks, a god among worldly men.

 - **Functionality:** When thrown it attracts enemies within an area and they begin to attack it even if they are chasing the players, it activates at the end of the trajectory and it lasts X seconds. The baker house collides with enemies. It's time and AoE depends on its rarity:
 - **Common: 3 seconds, area 10 times player hitbox**
 - **Rare: 4 seconds , area 12 times player hitbox**
 - **Epic: 6 seconds, area 15 times player hitbox**

- **Offensive Chip:**
 - **Description:** A thin layer made of aluminum bone, with thin and sharp canals, boosts the offensive capabilities. A fine piece of machinery, made with perfect precision.

- **Functionality:** This chip is an **equipable** item that gives a **velocity boost**, a **reload speed boost** and an **ability damage boost**. These **boosts depends on the rarity** of the chip:

- **Common:**

- **Rare:**

- **Epic:**

- **Defensive Chip:**

- **Description:** A thick layer made of aluminum bone, with many thin canals spread around various layers , boosts the defensive capabilities. A fine piece of machinery, made with perfect precision.

- **Functionality:** This chip is an **equipable** item that gives an **armor boost**. These **boosts depends on the rarity** of the chip:

- **Common:**

- **Rare:**

- **Epic:**

There's a **special item** that allows the player to **upgrade the weapon**, it has **no rarity**. It is the "**Alien core**". It works as a normal item, but it can only be used in the Upgrade Robot station. It can only be found in crates on raid. It's the most valuable item.

There's another special **craft** option that allows the player to get **more resin vessels**, it has **no rarity**. It works like all the crafts but when the item is picked from the crafting slot automatically disappears and the max resin vessels get upgraded to one more.

Crafting Guide

Armor: Alien Skin + Alien Skin + Alien Exocranium

Offensive Chip: Alien Claw + Alien Claw + Alien Aluminium Bone

Defensive Chip: Alien Exocranium + Alien Exocranium + Alien Aluminium Bone

Resin Vessel: Alien Skin + Alien Acid Vesicle + Alien Tail tip

3.7 Crafting and Upgrading mechanics

In the base, the player will have two stations:

3.7.1 Crafting Station (Caius)in

- In the crafting station, managed by Caius, the player can use the materials dropped by the enemies to get useful items.
- To use the station the player has to interact with it by using the A button, and the B button to stop using it (if the player is holding an item it can't be closed).
- Once used, a menu pops up, showing all the possible crafts and the inventory
- Each craft will have the icon silhouette of the items needed for the craft as well as an icon showing the crafted item.
- The player can move the items from the inventory to the crafting slot using the same control system as the inventory and equipment (pressing A to pick an object and A again to drop it). If the player tries to place an item in the wrong crafting slot it won't be placed and a sound will be played.
- Once the player places all the items needed for a craft, these will be deleted automatically and the crafted item will appear in the pertinent slot on the menu.
- The player can pick up the crafted item and place it in the inventory (there will always be room for the item since at least 2 are used to make a craft).
- If the player closes the menu and there's one item or more in the crafting menu, all those items will be placed in the first free slot found in the inventory one by one.

3.7.2 Upgrade Weapon Station

- In the upgrade station the player can use the alien cores to upgrade the 3 possible weapons.
- When the player interacts with the station a menu pops up and shows the 3 weapons and their corresponding skill tree, also, it's shown an icon of an alien core and a number equal to the total of alien cores owned by the player (in the inventory and in the base stash).
- The player can use the B button to stop using the Upgrade Station.
- On the skill tree the player, by moving the Left Stick, can hover between available skills to see its description and cost.
- The player can use the A button to obtain the skill hovered if he has the alien cores required for that skill. If he doesn't have enough alien cores, nothing happens and a sound is played.
- A skill is unlocked when the previous one is upgraded. The player can only hover between the unlocked skills.

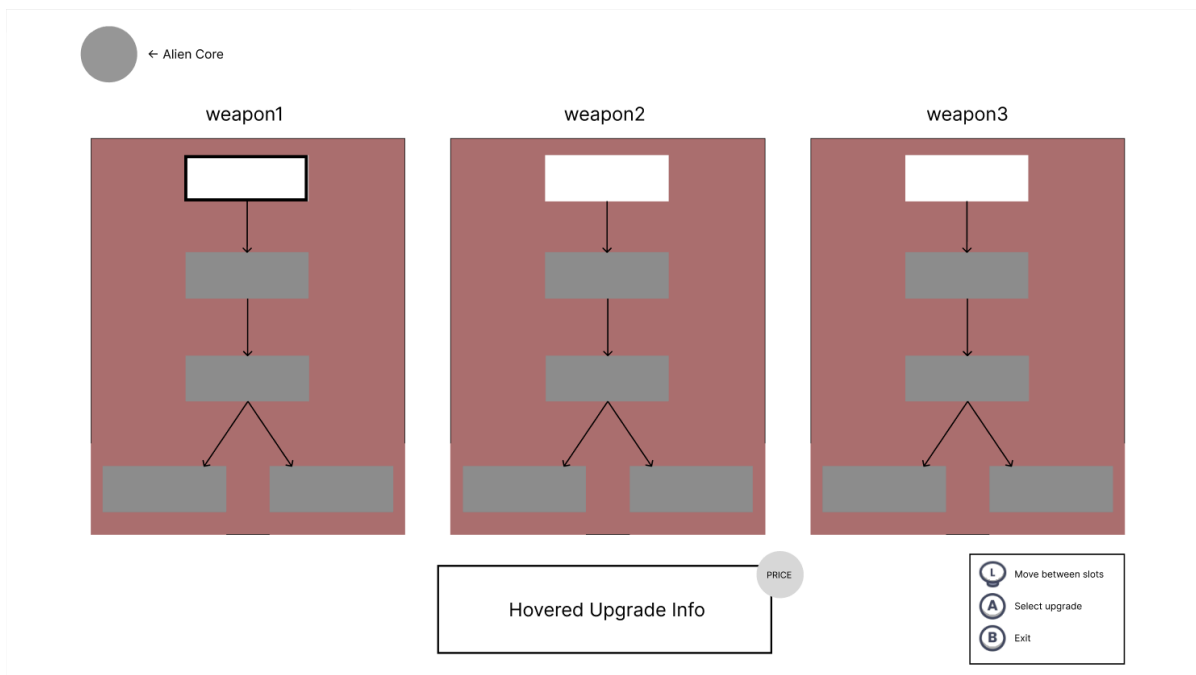

Upgrade weapon menu wireframe

3.8 Objectives

3.8.1 Short-term Goals (within levels)

On the first two levels you have two different principal objectives, and you only can do one of them: go to the extraction point and return to the base or pass to the next level.

If you choose to extract, you will have to find the extraction point marked on the map.

If you choose to pass to the next level, you will have to find the door to the next level marked on the map.

Secondary objectives on this levels are research materials to become stronger. You can get this material by exploring or killing the enemies.

The objective of the last level is to find a way to access the boss room and kill the Alien Queen that is waiting for you in that room.

3.8.2 Long-term Goal (overall game)

The final goal is to clear the Hatchery, eliminate all forms of life and come back alive to the ship. On the way, nevertheless, you will have to overcome some difficult information about yourself.

The player starts out not knowing who is counting on his services, what they have to do, nor even why.

As this is a secret mission, the level of information received by the company is minimal. However, the player will know that they have to go down to the planet and kill, this being the main mission: "eradicate all forms of life".

The story will unfold through different interactables throughout the levels, and the little information that can be contrasted with Caius.

The queen represents the last life form on the planet, so by eliminating her, the player returns to the ship and wins the game.

4. Weapons

The three classes of weapons that will be in the game are:

- **Firearm Class**
- **FSAD Class** (Firearm Specialized in Area Damage)
- **Plasma Weapon Class**

In each class there will be a main weapon, which will be the one we start the game with and as we progress, the weapon will be upgraded. The only difference with the evolutions will be that in the third of each class, which will be the last evolution, there will be two variants of the same weapon, but with different characteristics.

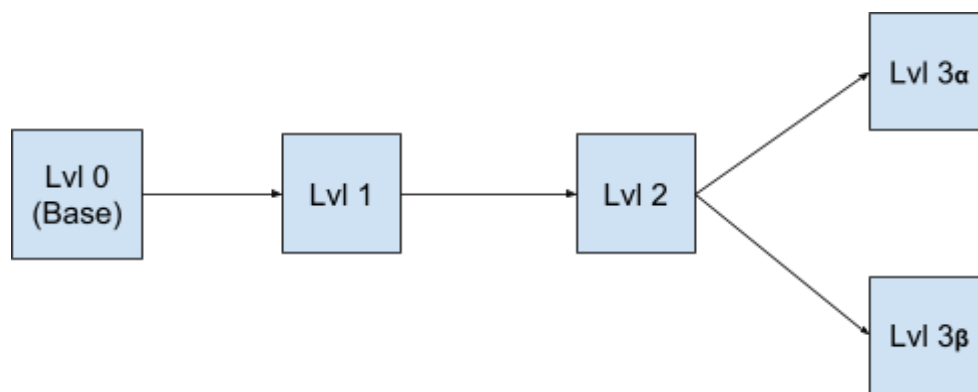

Example of the skill tree for any of the three weapons

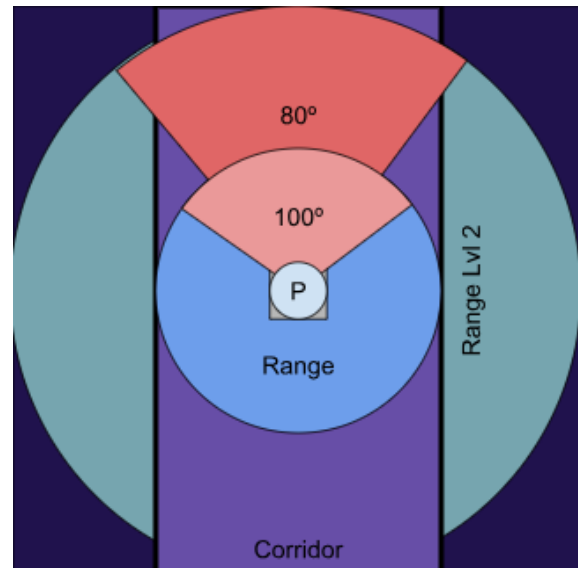
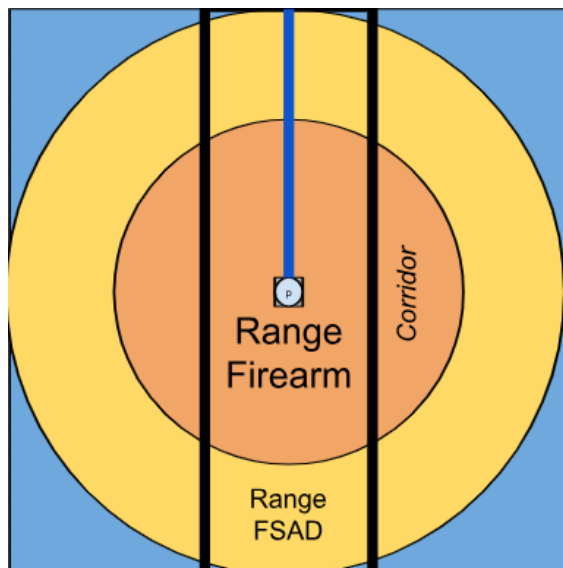

Visual example of ranges of the three weapons classes

4.1 Firearms

The **Firearm Class** is the most basic class in the entire game, as it is the one with the weapon with ballistic ammo and is the oldest class next to the FSAD.

This class has an assault submachine gun, which will be the most basic of all the evolutions or weapon upgrades of this class.

The main feature that sets it apart from the other classes is its rate of fire and agility. It will have a high rate of fire but low damage trade-off compared to the other classes.

Level 0 submachine gun (S.T.A.P.L.E.R.):

Pale and dark colors, playing with the half-rusted and worn material of the weapon.



- **Ammo per magazine:** 35 bullets
- **Rate of fire:** 0,06
- **Damage:** 5 per hit (83,33 DPS)
- **Reload time:** 1.8 s
- **Range:** 20 times Hit Box player (30 meters on unity)

Upgrades will be as follows:

Level 1 submachine gun (S.T.A.P.L.E.R. v1.5):

Slightly more modern colors playing with lighter tones, getting closer to white. Being a damage improvement, the skin will vary both in color and material, which will be a material with a plastic texture, where the light is reflected a little more when contacting the weapon. Blue and white will predominate over red.



Increased damage (double shot): The damage of each bullet fired is worth almost 2

- **Ammo per magazine:** 35 bullets
- **Rate of fire:** 0,05
- **Damage:** 9 per hit (180 DPS)
- **Reload time:** 1.6 s
- **Range:** 20 times Hit Box player (30 meters on unity)

Level 2 submachine gun (S.T.A.P.L.E.R. v2):

The colors used in this improvement will be the clearest and most vivid tones, using the range of orange and red, giving a more striking touch to the weapon. We went from a weapon with pale colors to one with a much warmer color palette.

The material used will be between matte and metallic. Orange and white predominate over black and gray tones.



Instant Reload by Dash: When the dash ability is activated, the weapon reloads automatically.

- **Ammo per magazine:** 40 bullets

- **Rate of fire:** 0,05
- **Damage:** 11 per hit (220 DPS)
- **Reload time:** 1.5 s
- **Range:** 20 times Hit Box player (30 meters on unity)

Level 3 submachine gun (S.T.A.P.L.E.R. α / S.T.A.P.L.E.R. β):

S.T.A.P.L.E.R. α

This upgrade and the next will have more unique and exotic colors and materials, giving the player much more motivation to want to obtain these two upgrades.

In this variant, we will have a weapon that will use a range of dark colors, where black will predominate on the weapon. There will be two colors that, although little can be seen at first glance, give the weapon a much more characteristic touch referring to the world of Alien, which is the color alien green, and with certain touches of metallic copper brown on the weapon.

The specific material of the weapon will be metallic in the golden areas, and a slightly more opaque and solid material such as matte.



Boosted Weapon α : all stats are boosted but the most notable is the number of bullets per magazine, allowing a very constant damage.

- **Ammo per magazine:** 110 bullets
- **Rate of fire:** 0,04
- **Damage:** 13 per hit (325 DPS)
- **Reload time:** 1.3 s
- **Range:** 20 times Hit Box player (30 meters on unity)

S.T.A.P.L.E.R. β

This beta variant will be similar to the color palette of the alpha variant, but inverted. The predominant colors here will be copper and gold colors, and the secondary colors will be matte black and brownish colors.

The material used will be a metallic material, giving more importance to bright colors. The color green will not be used at any time during this improvement.



Boosted Weapon β : all stats are boosted but the most outstanding one is the rate of fire gaining a very high damage in exchange for exhausting the magazine very fast.

Ammo per magazine: 40 bullets

- **Rate of fire:** 0,02
- **Damage:** 10 per hit (500 DPS)
- **Reload time:** 1.5 s
- **Range:** 20 times Hit Box player (30 meters on unity)

4.2 Firearm Specialized in Area Damage

The **FSAD Class** is the second class in the game. The look of the weapons is advanced in terms of futuristic design, but still has the same utility.

The weapon of this class is the scattergun, whose main ability is to fire a burst of pellets at a wide-range angle (100°).

Its main feature is its area damage and its close-in damage. That is, enemies close to the weapon will take more damage than if they are further away.

Level 0 shotgun (SPAR-X):

Pale and dark colors, playing with the half-rusted and worn material of the weapon. The dark wine red color predominates, although the oxidized black color is also quite noticeable on the weapon.



- **Ammo per magazine:** 16 bullets
- **Ammo in chamber:** 2 bullets

- **Rate of fire:** 1,3
- **Damage:** $55 * 2 = 110$ (85 DPS)
- **Reload Time:** 2,7
- **Range:** 7 times the range of the player hitbox (10,5 metros en Unity)
- **Dispersion angle:** 100°
- **Expected enemies to hit:** 2

Upgrades will be as follows:

Level 1 shotgun (SPAR-X v1.5):

The colors used in this improvement of the FSAD are pearl white tones, going from that oxidized material with dark tones to a completely opposite tone.

The materials that will be used will be materials that reflect light a little, giving that touch of purity of the white on the weapon. Not only white colors will be taken into account, but black tones will continue to be in the weapon, with a more opaque material than white.



Extended Magazine: The magazine's bullets are increased to 10 more bullets ($16 + 10 = 26$ bullets per magazine).

- **Ammo per magazine:** 26 bullets
- **Ammo in chamber:** 2 bullets
- **Rate of fire:** 1,2
- **Damage:** $70 * 2 = 140$ (117 DPS)
- **Reload Time:** 2,6
- **Range:** 7 times the range of the player hitbox (10,5 metros en Unity)
- **Dispersion angle:** 100°
- **Expected enemies to hit:** 2

Level 2 shotgun (SPAR-X v2):

The color palette that predominates in this evolution of the FSAD weapon is gold and white. It must be taken into account that the design of the weapon must be similar to this, with the muzzle much longer or adding an accessory.

The materials used in said weapon will have to be metallic and shiny enough.



Long Barrel muzzle application: Increased range of the shotgun, increasing from short range to medium range.

- **Ammo per magazine:** 26 bullets (13 shots before recharge)
- **Ammo in chamber:** 2 bullets
- **Rate of fire:** 1,2
- **Damage:** $75 * 2 = 150$ (117 DPS)
- **Reload Time:** 2,5
- **Range:** 12 times the range of the player hitbox (21 metros en Unity)
- **Dispersion angle:** 80°
- **Expected enemies to hit:** 4

Level 3 shotgun (SPAR-X α / SPAR-X β):

SPAR-X α

This improvement will have a different appearance from the others, adding biological parts of an alien on top of the weapon (it is clearer in the reference).

The colors used in this improvement will be the dark green and black colors, giving a more characteristic touch to this saga or alien theme. The dark green tones will be on top of these biological parts, and a brighter green tone in certain areas of these parts. Black will predominate in all the rest of the weapon.

The materials used will be matte materials, although in the bright green area it will be with a touch of more lighting.

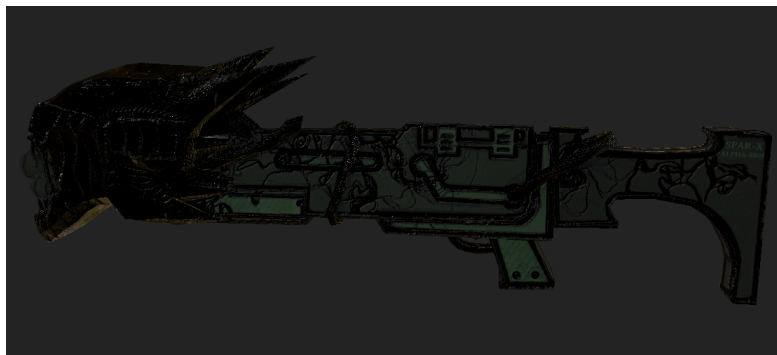

Boosted Weapon α : all stats are boosted but the one that stands out the most is the shotgun's rate of fire.

- **Ammo per magazine:** 28 bullets (14 shots before recharge)
- **Ammo in chamber:** 2 bullets
- **Rate of fire:** 0,7
- **Damage:** $80 * 2 = 160$ (230 DPS)
- **Reload Time:** 2,1
- **Range:** 12 times the range of the player hitbox (21 metros en Unity)
- **Dispersion angle:** 80°
- **Expected enemies to hit:** 4

SPAR-X β

This beta variant will be quite different from the alpha variant if we talk about appearance or skin design. The colors that will predominate will be the very bright pearl white tones and the shiny dark blue/green on the stock and handle of the weapon. On the front of the weapon, it will be given a bright purple touch.

The materials, as mentioned above, will all be bright, although in order, the brightest will be white, the second will be blue/dark green, and the third will be purple.

In the reference attached below, you can see how the weapon should look, with the shiny white part protruding from the weapon, and with alien touches such as the tentacles at the bottom.



Boosted Weapon β : instead of 2 bullets, the shotgun chamber will have 4 bullets, greatly increasing its damage at the cost of cadency and number of shots per magazine.

- **Ammo per magazine:** 28 bullets (7 shots before recharge)
- **Ammo in chamber:** 4 bullets
- **Rate of fire:** 1,3
- **Damage:** $80 * 4 = 320$ (246 DPS)
- **Reload Time:** 2,5
- **Range:** 12 times the range of the player hitbox (21 metros en Unity)
- **Dispersion angle:** 80°
- **Expected enemies to hit:** 4

4.3 Plasma

Finally, the **Plasma Weapons Class** is the third weapon class in the game and is the most technologically advanced.

The weapon that represents this class is the **EM-MK2** or "ElectroMagnetic-Mark 2", a weapon that launches a plasma laser through an electromagnetic mechanism. It is an upgraded version of a well-known weapon of the future.

The main difference with firearms is that it does not have bullets as such, but is a plasma cannon with continuous damage that overheats, gaining damage the longer it is shot in a continuous way. Although it has a bullet counter, the number of bullets will gradually decrease until the plasma ammunition magazine is depleted, which will be exchanged for a new one.

Level 0 plasma cannon (EM-MK2):

The predominant colors of the EM-MK2 base weapon are going to be very basic colors at first, to give a much higher touch of improvement.

Rusty tones of blue, brown and a little khaki green predominate.

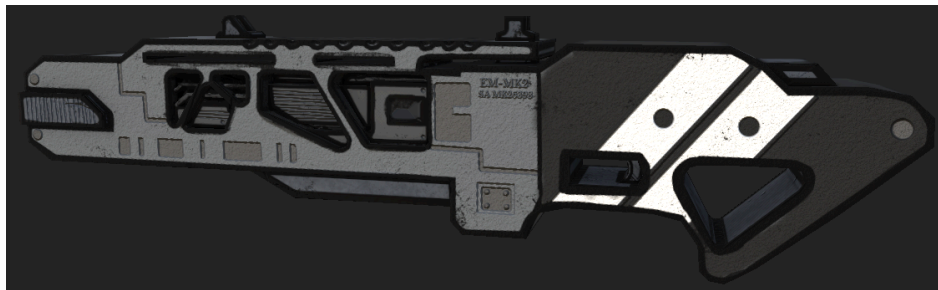

- **Ammo per magazine:** 200 bullets
- **Rate of fire:** 0,03
- **Damage:** 2,4 (80 DPS)
- **Damage Escalation:** 0,06
- **Reload Time:** 3
- **Range:** 40 times Hit Box player (60 meters on unity)

Upgrades will be as follows:

Level 1 plasma cannon (EM-MK2 v1.5):

In the first evolution of the Plasma Weapons, there will be a change in color and material, from dark and cold tones with an oxidized material, to slightly warmer tones with opaque materials that do not reflect much light and without being oxidized.

The appearance of the weapon will be the same as that designed in the blueprints, but the following references are used to see how they look on weapons with similar appearances.

The colors used are hope red tones, a little sky blue in certain points of the weapon, and on the front it will have a touch of matte black.



1. **Fast Loader:** The loading time of the magazines of this weapon is decreased to two thirds of the time.
 - **Ammo per magazine:** 200 bullets
 - **Rate of fire:** 0,03
 - **Damage:** 3 (100 DPS)
 - **Damage Escalation:** 0,01
 - **Potential Extra Damage / Magazine:** 201
 - **Reload Time:** 2
 - **Range:** 40 times Hit Box player (60 meters on unity)

Level 2 plasma cannon (EM-MK2 v2):

In the second evolution, the colors change to a more orange tone at the top and dark bluish at the bottom. The materials used will be materials between plastic and matte, that do not reflect much light, but that give them a little more than in the previous evolution. It is emphasized again that until the last two improvements, which are always the boosted alpha and the boosted beta, nothing will be modified in terms of the appearance of the weapon or skin, only colors and materials.



2. **Extended Magazine:** The bullets in the magazines are increased to 100 more bullets (200 + 100 = 300 bullets per magazine).
 - **Ammo per magazine:** 300 bullets
 - **Rate of fire:** 0,02
 - **Damage:** 3,6 (180 DPS)
 - **Damage Escalation:** 0,01
 - **Potential Extra Damage / Magazine:** 452

- **Reload Time:** 2
- **Range:** 40 times Hit Box player (60 meters on unity)

Level 3 plasma cannon (EM-MK2 α / EM-MK2 β):

EM-MK2 α

The alpha boost variant of the latest improvement or evolution of the Plasma Weapons will have a very violent design, since convex angles will be used to give that feeling of power and aggressiveness to the player with this weapon.

The predominant colors will be red and black. You can give the red color a much more significant tone and lighting than what is seen in the reference shown below, giving it a more futuristic appearance. As the passive improvement of this evolution has to give much more damage in a reduced time, it is very surprising that this weapon design is the one used, because it looks like an aggressive weapon, and therefore, generating this sensation of aggression and mode unleashed on the player when using this upgrade.

The materials used in this improvement will be, in the black area a metallic without being very metallic (that is, it does not reflect much light to give importance to the red and pregnancy) and in red, it will be a material that gives a sensation like if it were illuminated.

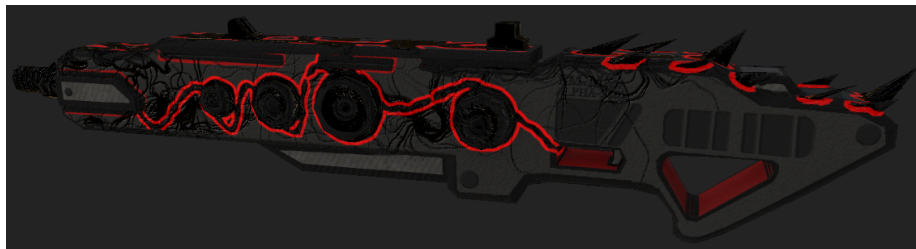

Boosted Weapon α : All stats are boosted but the most notable is that the weapon fires with more damage and with more speed, increasing the cadence. Also, the overhear damage increase of the weapon increases.

- **Ammo per magazine:** 300 bullets
- **Rate of fire:** 0,015
- **Damage:** 5 (333 DPS)
- **Damage Escalation:** 0,015
- **Potential Extra Damage / Magazine:** 677
- **Reload Time:** 2
- **Range:** 40 times Hit Box player (60 meters on unity)

EM-MK2 β

The beta variant changes radically both in appearance and color palette. The appearance of the weapon will not be radically different as with the alpha variant, but it is necessary that this change be noticed compared to the previous improvements.

In the reference you will see in more detail what the appearance of the weapon will be like, which will have shiny golden features (in the reference the golden material is not shiny but it

will have to be changed to a very shiny material as in other previous weapons) and in between Dark bluish tones of matte material will predominate.

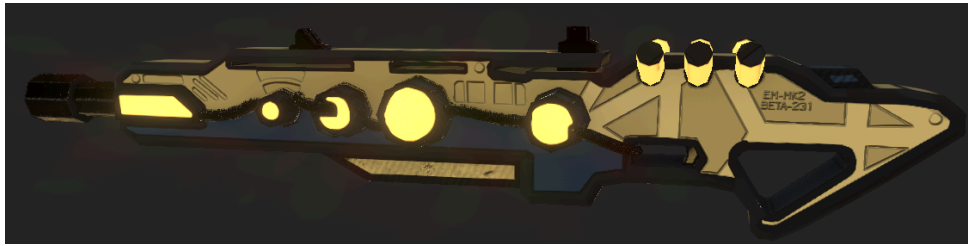

Boosted Weapon β : all stats are boosted but the most notable is that the laser goes through enemies, making it possible to make collateral casualties.

- **Ammo per magazine:** 200 bullets
- **Rate of fire:** 0,02
- **Damage:** 4 (200 DPS)
- **Damage Escalation:** 0,01
- **Potential Extra Damage / Magazine:** 452
- **Reload Time:** 2
- **Range:** 40 times Hit Box player (60 meters on unity)

4.4 Weapons Particles

The bullets in the Firearms Class and the FSAD classes will not be seen, but only the color of the muzzle flash particles that will come out of the weapon and their respective color will be taken into account.

Firearms y FSAD:

When the player fires, a bright, focused flash will emerge from the weapon, accompanied by small sparks that will disperse into the air. This muzzle flash will be more pronounced and expansive for the FSAD, reflecting the greater bullet dispersion characteristic of a shotgun.

In addition to the muzzle flash, you can add smoke effects or residual gases that are released from the weapon after the shot, intensifying the feeling of power and realism. These particle effects will not only serve to enhance the visual aspect of the game, but also provide tactile feedback to the player about the shooting action, which will increase immersion in the gaming experience.

- **Base, 1st Upgrade & 2nd Upgrade:**

The bullets of the base evolution, first evolution and second evolution will be a basic color, as if it were a normal firearm. A flash of fire comes out of the weapon, which will be one of the particles that will predominate in this class and in the FSAD, and the bullets as such will not be seen.

The color palette of these particles will be from white to red and yellow, giving touches of fire.



- **3rd Upgrade (Alpha Boost & Beta Boost):**

The color of the flash particles will be red and blue. The clear reference to these particles is within the COD: Black Ops zombie saga. In this game, when the weapon is improved, it is specifically seen that the color palette of the particles of the bullets with the muzzle flash are that color.



Plasma Weapon Class:

For Plasma Weapons class weapons, the particle effect will be crucial to represent the intensity and power of the plasma beam.

When the player fires, a bright, concentrated beam of plasma will extend forward from the weapon. At the start of the weapon, a spherical beam slightly larger than the beam will create an energy emission effect, emphasizing the point of origin of the shot.

When the plasma beam comes into contact with an enemy, additional energy particles will be generated and spread from the point of impact, giving the impression of a violent collision. These particles will add an element of dynamism and realism to combat encounters, helping to visually communicate the damage inflicted and the power of plasma weapons.

- Base, 1st Upgrade & 2nd Upgrade:

This class does not have bullets as such, but is a laser that inflicts damage when it is activated, the ammunition or energy progressively decreases as it is used. The color of this beam in the base state and in the first two upgrades will be red, as it is the best-known default color of a laser beam.

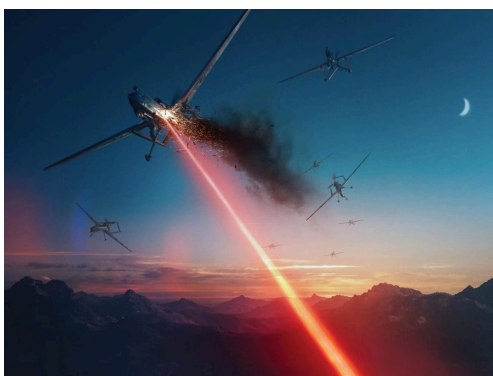

- **3rd Upgrade (Alpha Boost):**

The color of the laser on this weapon will be green as in the reference shown below. It is the default color that was used in the Call Of Duty: Advanced Warfare weapon, a weapon used to have as a reference what the EM-MK2 weapon would be like.



- **3rd Upgrade (Beta Boost):**

The color of the laser on this weapon will be fuchsia pink. as in the reference shown below. It is the default color that was used in one of the legendary variants of the Call Of Duty: Advanced Warfare weapon, which has more damage than the others. Since this improvement has collateral damage as a passive, it makes sense that the best weapon of these variants is exactly the one that refers to this one.



5. Enemies

The idea is to use the Xenomorph species as the main enemy, using different variants of it so that there is variety in terms of enemies.

[Figma Link](#)

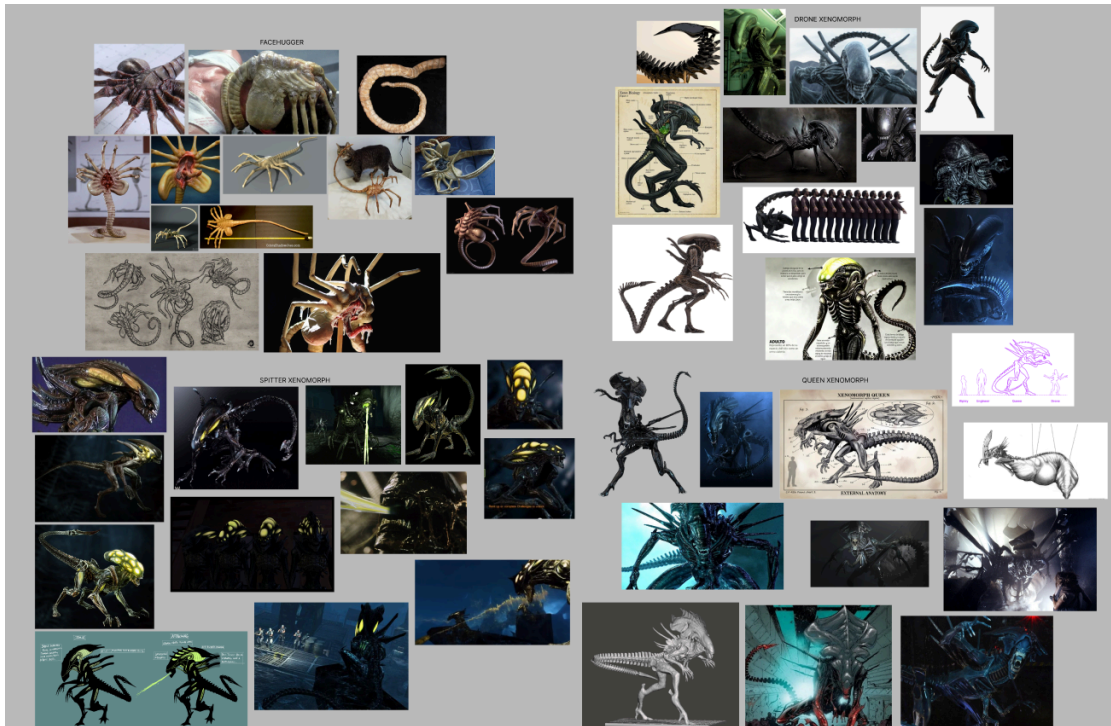

Enemies UI

Each enemy will have a small health bar on themselves. The color will correspond to its rarity.

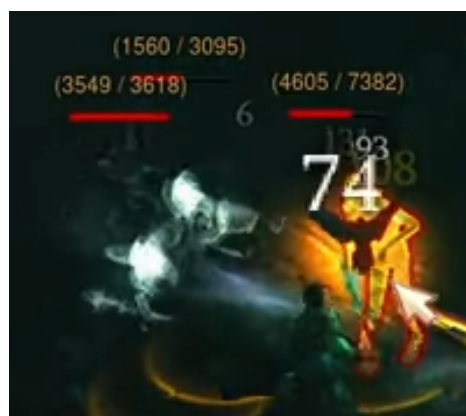

5.1 Facehugger

Description

This enemy hatches from Alien eggs once it detects some source of heat or a noise external to the egg. Once it has hatched from the egg it cannot re-enter and has a fairly short life span, which can range from hours to a few days.

Physical description

It is the first life form of the Xenomorph, has light brown skin, an arachnid complexion, legs resembling the fingers of a hand, and a long tail that it uses to grip the neck of its victim while releasing a substance to numb it. It has tubes coming out of its mouth, one to introduce the parasite into the host, and the other to provide it with enough oxygen until it is needed.

Average height: 0,2m.

Average tail length:

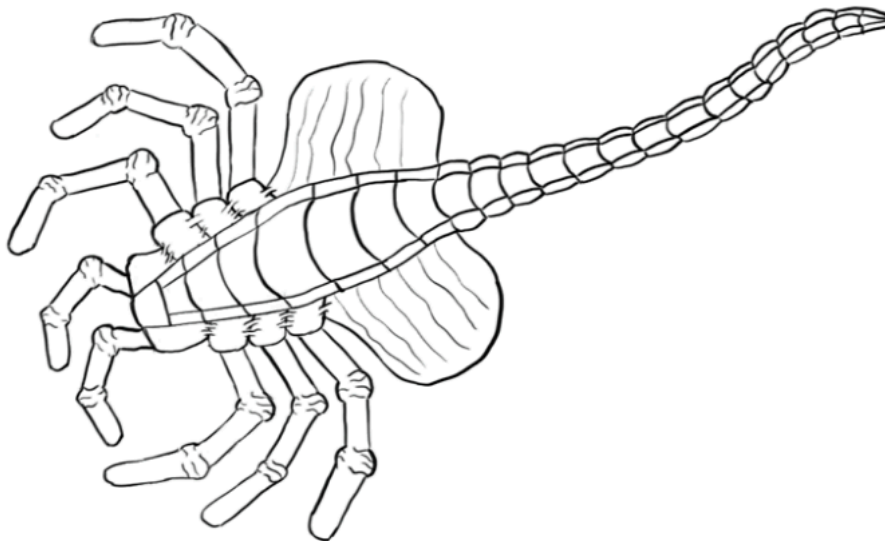

Facehugger concept art

Specifications

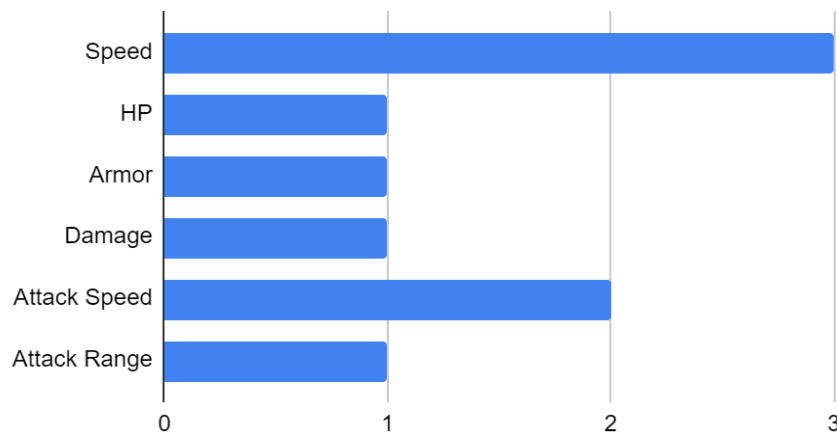

Stats

	Type	HP	Armor	Speed
Facehugger	Basic	120	0	15
	Rare	330	0.1	16.5
	Epic	440	0.2	18

Animations

- **Idle:** The facehugger is perched on its 8 legs.
- **Combat Idle:** After making the "cry" animation, it means that it has located the player and goes to a more aggressive state, raising its tail a little, ready to attack.
- **Cry:** Once it locates the player, the facehugger raises its front legs while screaming.
- **Move:** It has a spider-like movement, seen in [Enemies Video References](#) .
- **Tail attack:** The facehugger jumps and uses its tail to whip its enemy hard.
- **Death:** The facehugger turns on its back and shrinks its legs.



Facehugger death pose reference

5.2 Drone Xenomorph

Description

In the hive hierarchy, the drone is in the lowest position, representing 80% of the hive population. Its functions in the hive are: to build the hive, to search for food and creatures to infect, and to protect the eggs. If the drone is not able to fulfill its functions, it will offer itself as food for the queen, since its top priority is to keep the queen alive.

Physical description

Its skin is dark gray. Compared to others of the same species, its body is thin, and its head is smooth with a white membrane. Its tail is also the thinnest and weakest in the hive, but it is not a weak enemy and is capable of doing a lot of damage with it. It has some resistance to burns, weak weapon shots, and small explosives.

Average height: 2,5m.

Average tail length: 4m.

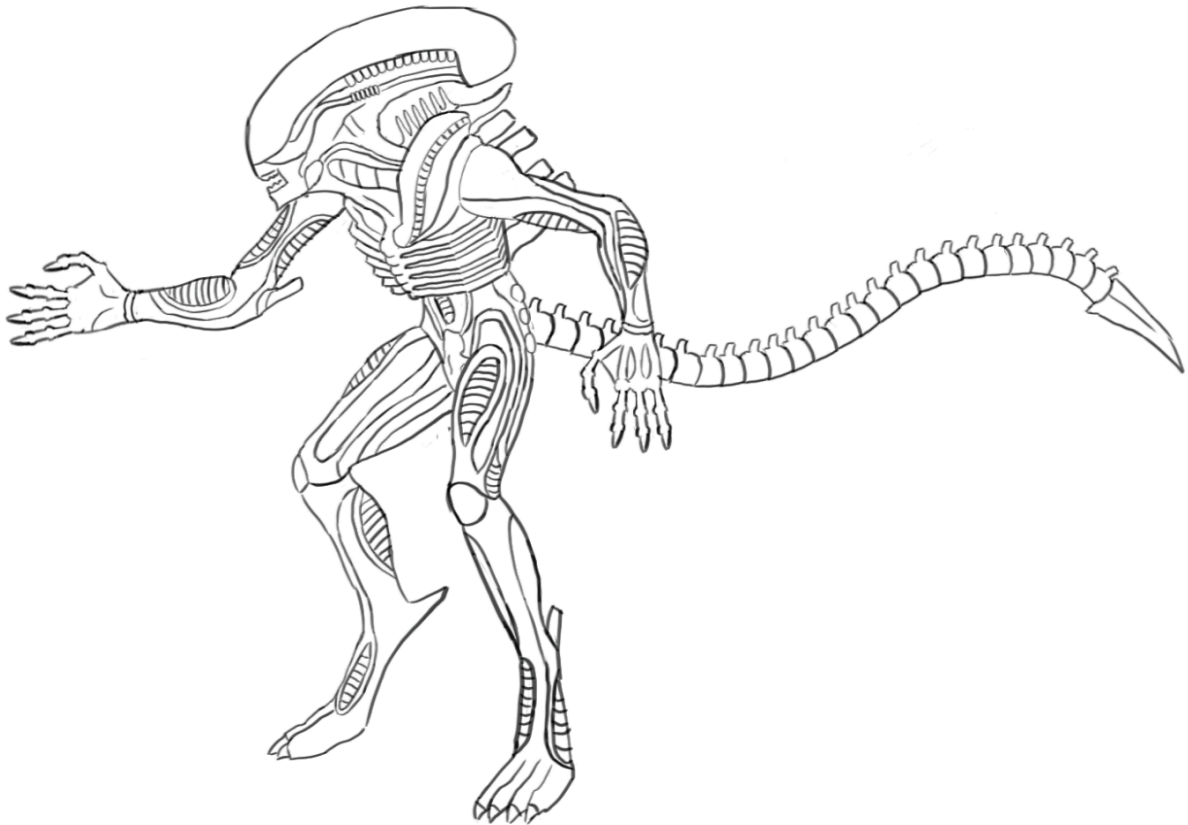

Drone Xenomorph concept art

Specifications

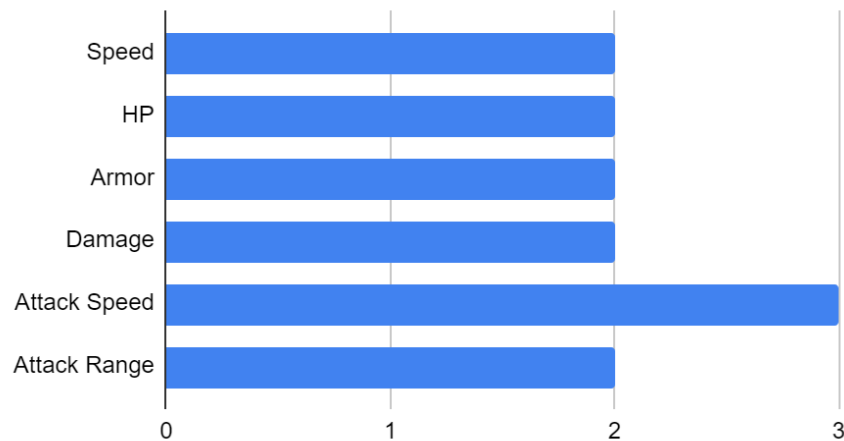

Stats

	Type	HP	Armor	Speed
Drone Xenomorph	Basic	300	0	11
	Rare	600	0.1	12.1
	Epic	800	0.2	13.2

Animations

- **Idle:** The drone xenomorph is standing on 2 legs.
- **Move:** The drone xenomorph can move on 2 or 4 legs. It moves on 2 legs when it is calm, and on 4 legs when it is chasing the player. It can be seen better in [Enemies Video References](#).
- **Cry:** Once it locates the player, the drone xenomorph opens its mouth to scream and goes into "combat idle" animation.
- **Combat Idle:** After doing the "cry" animation, it means that it has located the player and goes to a more aggressive state, landing on 2 legs with an attack pose, preparing its claws.
- **Death:** The drone xenomorph falls backwards to the ground.

Attacks

- **Claw attack:** The Xenomorph would make a forward attack using its powerful claws.
 - 150 DMG Points.



- **Spiked tail:** The Xenomorph uses the sharp end of its tail to stab forward at the enemy.

- 200 DMG Points.

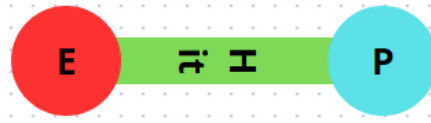

Behavior diagram

This Xenomorph seeks to get close to its enemy to attack it with its powerful claws. In case it cannot get close enough to its enemy, it seeks to use its long, withering tail to make mid-range attacks.

Its diagram would be practically the same as that of the facehugger, with the difference that it would take into account the player's distance to execute one attack or another.

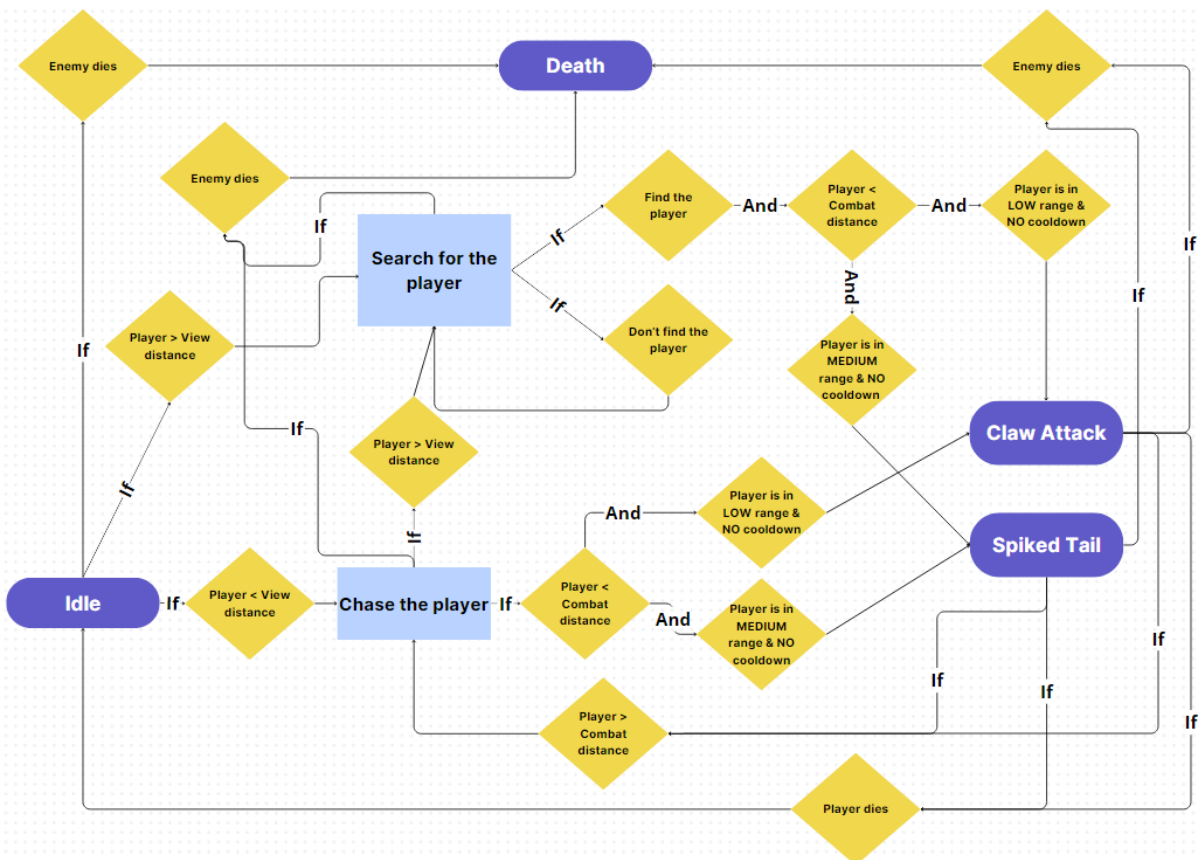

Loot

- **Global Rate Drop: 20%**
 - **Alien resin: 10%**
 - **Alien claw: 30%**
 - **Alien tail tip: 30%**
 - **Alien exocranium: 30%**

5.3 Xeno Spitter

Description

This variant is an evolutionary response to human weaponry such as automatic turrets, vehicles and armored luggage among others. This variant offers the Xenomorph species more balance in battle, being able to cover the battle from a distance by firing acid, allowing it to damage armored elements and wear them down.

Physical description

It has black skin. On its head it has bright greenish-yellow pouches that are salivary glands that have developed to spit acid more effectively. Its head is oval-shaped like the drone, with spikes protruding from the head, and in turn has a kind of crown like the queen. On the sides of its face it has two small horns. Its teeth do not end in a point like those of the drone, since they have not developed as much because they are dedicated to combat at a distance, and thus allow a better firing of its acid projectiles. Looking at his torso, he has a greenish-yellow color behind his ribs, which would be the lungs that he would also use when spitting acid. Two spikes protrude from his elbows. The protuberances on its back are larger than those of a drone, in addition to ending in a point. It also has a protuberance on the back of its neck, like the drone. Its tail ends in two points, giving it the shape of an axe.

Average height: 2,5m.

Average tail length: 4m.



Xeno Spitter concept art

Specifications

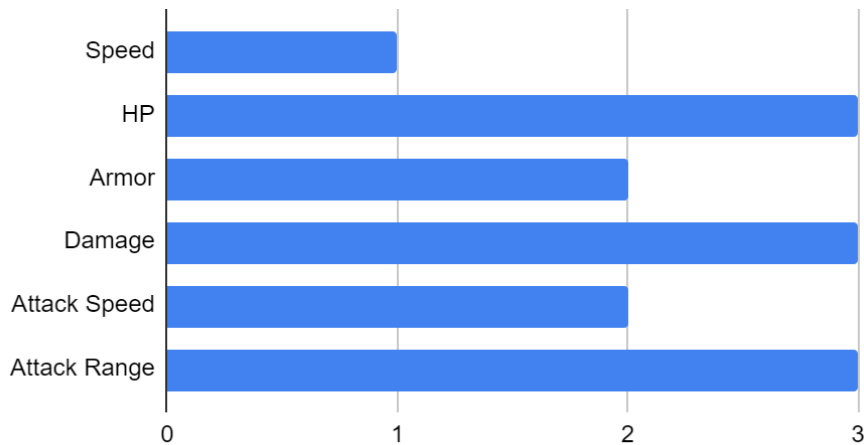

Stats

	Type	HP	Armor	Speed
Xeno Spitter	Basic	425	0	9
	Rare	787,5	0.1	9.9
	Epic	1050	0.2	10.8

Animations

- **Idle:** The xeno spitter is standing on 4 legs.
- **Move:** The xeno spitter moves on 4 legs. It can be seen better in [Enemies Video References](#).
- **Cry:** Once it locates the player, the xeno spitter opens its mouth to scream and goes into an attack pose.
- **Combat Idle:** After doing the "cry" animation, it means that it has located the player and goes to a more aggressive state, preparing to attack.
- **Death:** The xeno spitter falls face down to the ground.

Attacks

- **Acid spit:** The Xeno Spitter unleashes a stream of potent hydrofluoric acid from external pouches on the side of their skull. This stream will be represented by particles of green color (24, 106, 59, 130) that rapidly advance forward and then fall to the ground. These particles would have a lifetime and speed randomized to change where they spawn.
 - 300 DMG Points

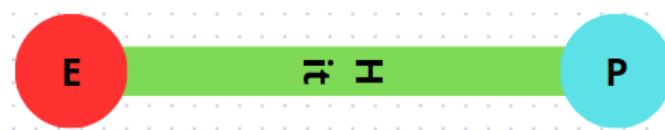

- **Acid burst:** The Xeno Spitter spits a strong and unstable sphere projectile. If that spit doesn't reach its target in a certain range, it bursts into smaller projectiles. The object will leave a trail of particles on its back of the same green color as its other attack that have an x and y randomized value and fall like they have gravity.
 - **Big projectile:** 350 DMG Points
 - **Small projectile:** 150 DMG Points

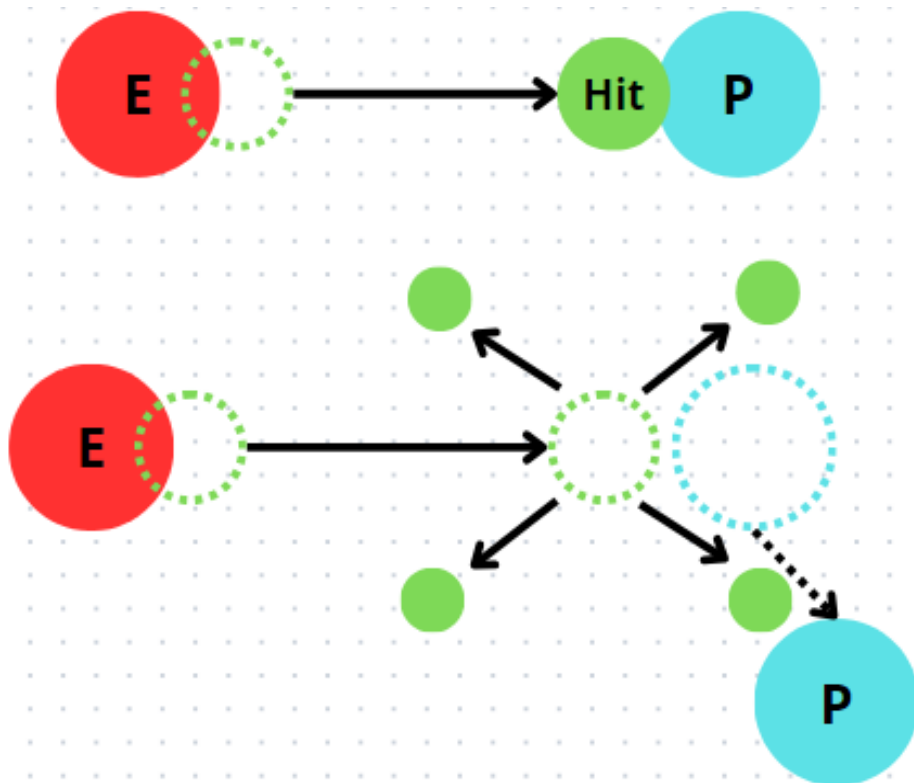

5.4 Enemy rarities

There are enemies that within their own group may be stronger than others. Taking this into account, enemies can be divided into 3 types:

- **Basic:** The enemy will have nothing distinctive to differentiate it from others.
- **Rare:** The enemy will have a blue aura that differentiates it from other enemies. These have a 5% chance of appearing. Rare enemies hit harder than their basic counterparts. The improvements in stats are:
 - HP Basic * 1.5 + 50
 - Armor Basic + 0.1
 - Speed Basic * 1.1
 - Attack * 1.15 + 30
 - Drops will always be of rare objects
- **Epic:** The enemy will have a purple aura that will differentiate it from the other enemies. These have a 2% chance of appearing. Rare enemies hit much harder than their rare counterparts.
 - HP Basic * 2 + 100
 - Armor Basic + 0.2
 - Speed Basic * 1.2
 - Attack * 1.3 + 50
 - Drops will always be of epic objects

Enemy total HP

“HP by range”/(1-“Armor by range”)

5.5 Queen Xenomorph

Description

It is the last evolutionary stage of the species. Its level of intelligence is higher than that of the other xenomorphs and it is in charge of leading and exercising power over all the xenomorphs. She is the most important part of the hive and all the xenomorphs would be capable of dying for her. She is in charge of laying the eggs from which the facehuggers hatch. While the queen is only in the hive laying eggs, she is usually hanging from the ceiling thanks to a resin secreted by the xenomorphs, her reproductive apparatus is similar to that of a termite queen, and from it she expels the eggs once they are ready. In this case, the queen is hung from the wall by chains, while the androids continue to study her species. These chains also hold her tail. This makes her weaker and more vulnerable, relying mostly on the xenomorphs to protect her and her eggs. Should the other xenomorphs be unable to protect the eggs, she can shed her reproductive apparatus and whatever else is necessary to fight the enemy and protect her hive. If necessary, the xenomorphs themselves offer themselves as food for her to survive.

Physical description

This queen has more complexion than the original queens. It has a large crest on its head, which serves as a crown and protective shell, since it can put its head inside it. This gigantic crest may seem somewhat disproportionate to the rest of its body, as it protects its brain, which it uses as an antenna to communicate with the other xenomorphs and receive thermal, biochemical and bioelectrical signals. It has a huge mouth with sharp crystalline teeth. It also has a retractable mouth. The queen's body is not as humanoid as other xenomorphs, but has more similarities to theropod dinosaurs. It has 6 joints in total. It has 2 hind legs on which it can stand upright. It has 2 large and strong arms, each ending in a hand with 6 fingers with very sharp claws. It also has 2 small arms coming out of its chest, but they are not of much use. It has its dorsal tubes like the other xenomorphs, however these seem sharper and end in a point. Its exoskeleton is extremely hard and tough, making it very resistant to the simplest bullets, small explosives and fire. The color of its skin is usually dark blue or black, but this queen's skin is lighter in color with scarlet tones. It has a very long and sharp tail that ends in the shape of an axe.

Average height: 7m.

Average tail length: 5,5m.



Queen Xenomorph concept art

Combat

- **Phase 1:** In this first phase, the queen will decide to face the player herself, freeing herself from the chains that bound her. In this phase, the queen will be able to approach you across the map and attack you with powerful scratches, swipes and headbutts, as well as maintaining the attacks of the previous phase. Once it loses half of its life bar, it would gain invincibility while doing the “cry” animation. After this, he loses invincibility and would pass to the second phase.
- **Phase 2:** The queen is enveloped in a purple aura. The queen receives a 1.5 damage buff on all her attacks. ‘Queen dash’ now does 3 attacks instead of 2.

Animations

- **Idle:** The queen is perched on 2 legs, in a threatening pose.
- **Move:** It can be seen better in [Enemies Video References](#) .
- **Move sideways:** The boss moves sideways, circling around the player while observing him.
- **Cry:** The queen xenomorph opens its mouth to scream.
- **Death:** The queen slowly falls to the ground (she dies an epic death).

Attacks

- **Acid throw:** The queen will be able to throw acid from long distances. It leaves puddles of acid. Similar to the spitter the attack would have a trail of particles of

green color with some transparency that slowly fall to the ground like it had gravity and with a random spread in the “X” and “Y” axis, but compared to the spitter the particles would be bigger.

- 450 DMG Points

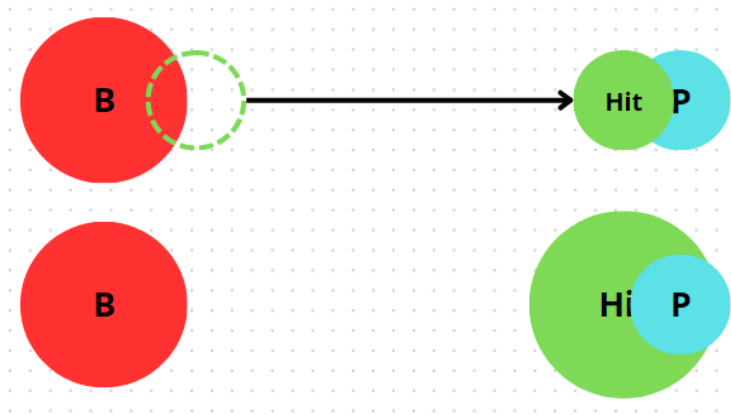

- **Queen claw:** The queen would make a forward attack using her powerful claws.

- 500 DMG Points

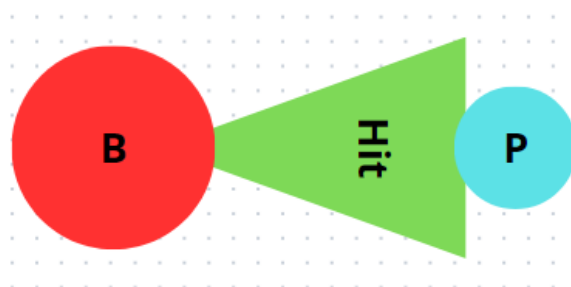

- **Axe tail:** The queen charges her huge tail for a few moments to drive it into the ground creating a strong blow in the area. The attack would create a crack on the ground using world oriented particles that always look upwards and will create small rubble-like particles that will spawn in a circle and will fall like it had gravity.

- 1000 DMG Points

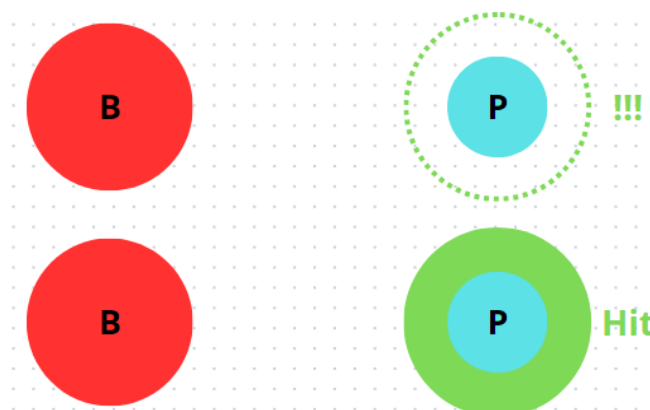



Particles idea, ours would be a lot less complex

- **Queen dash:** The queen will hide part of her head in her crown and start to charge at you in a sequence of 2 running attacks. Before she makes the attack, an indicator will pop up where she will attack (the indicator will follow the player until the attack is charged and at that point she will attack). This indicator will be marked by a circle of red particles. While she makes this attack, you cannot hit her with frontal shots, but you would have to shoot her from the sides or from behind.
 - 650 DMG Points

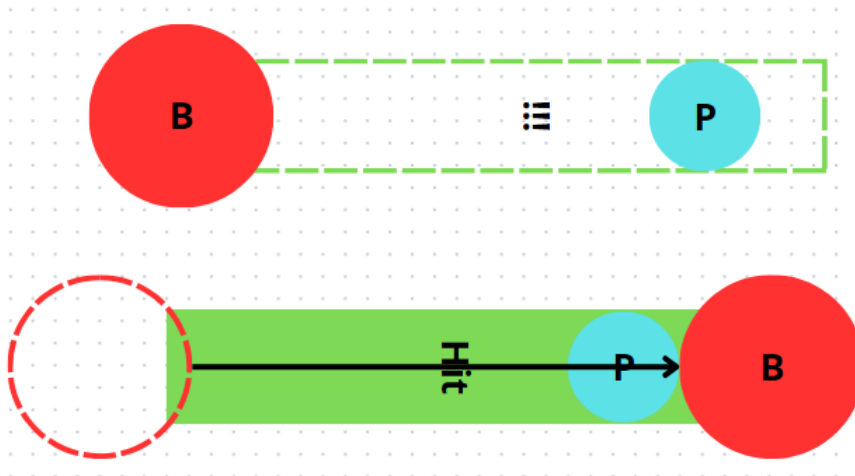

6. Level Design

6.1 Game Graphs

Game Flow

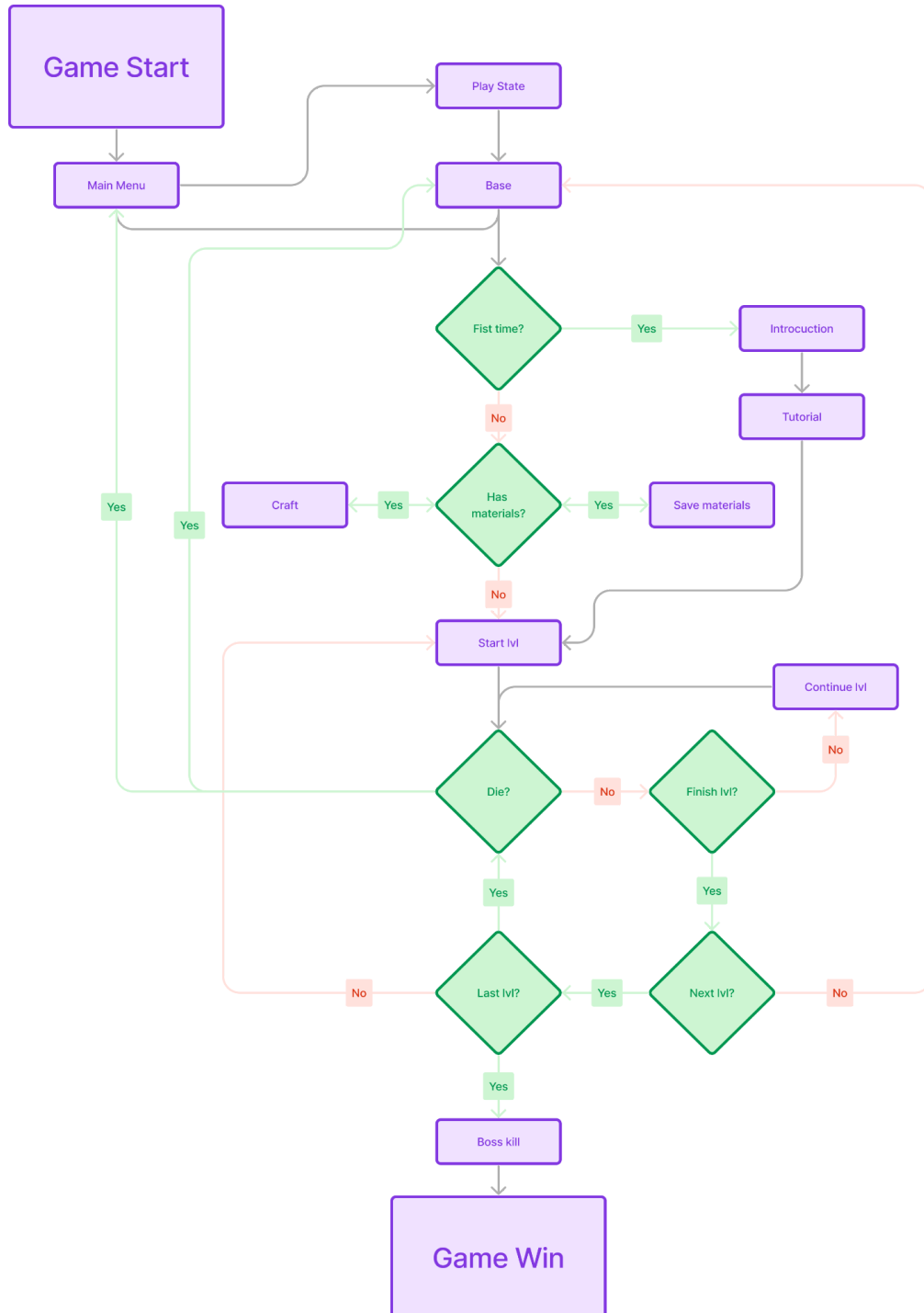

LVL 1

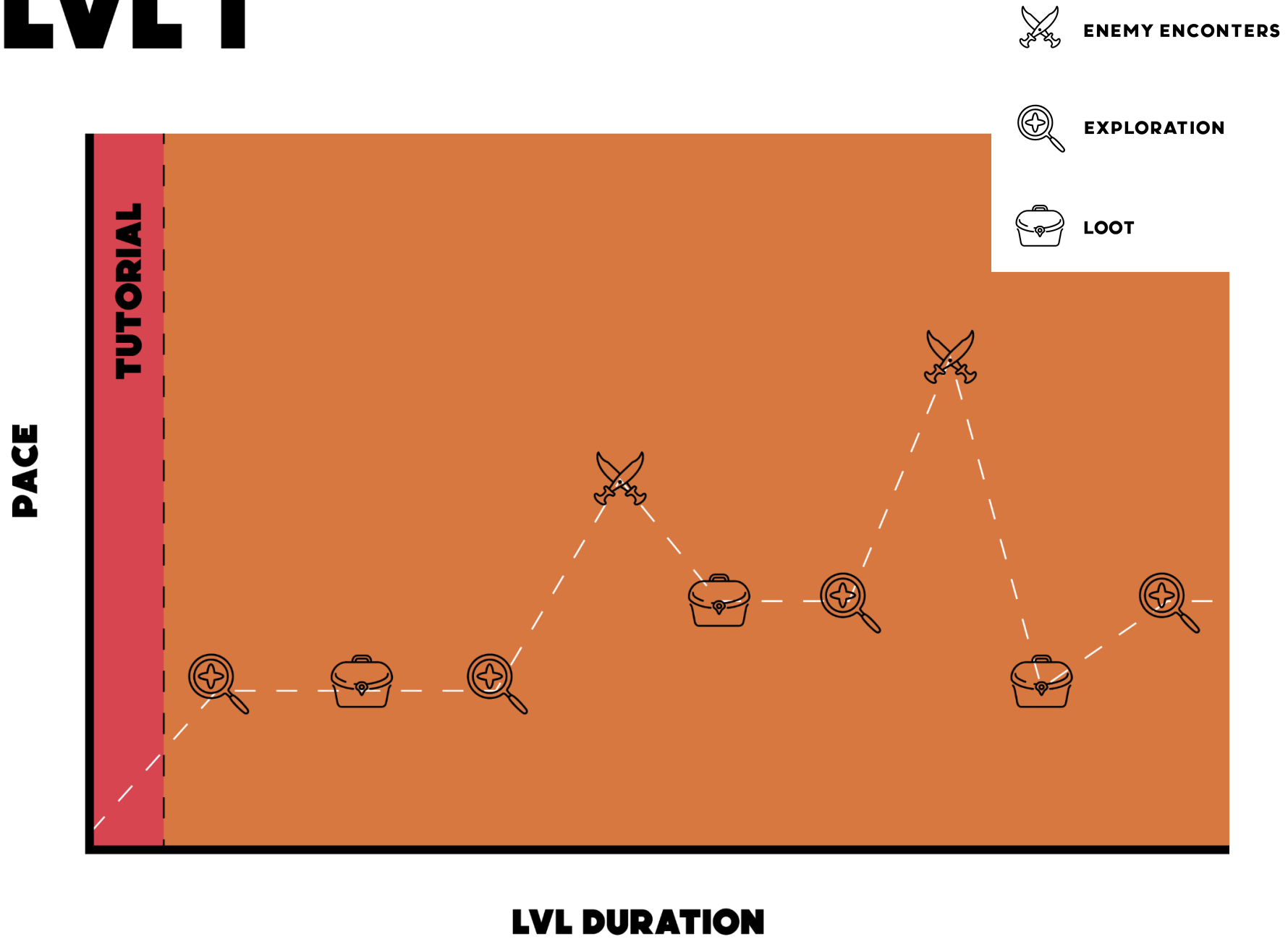

LVL 2

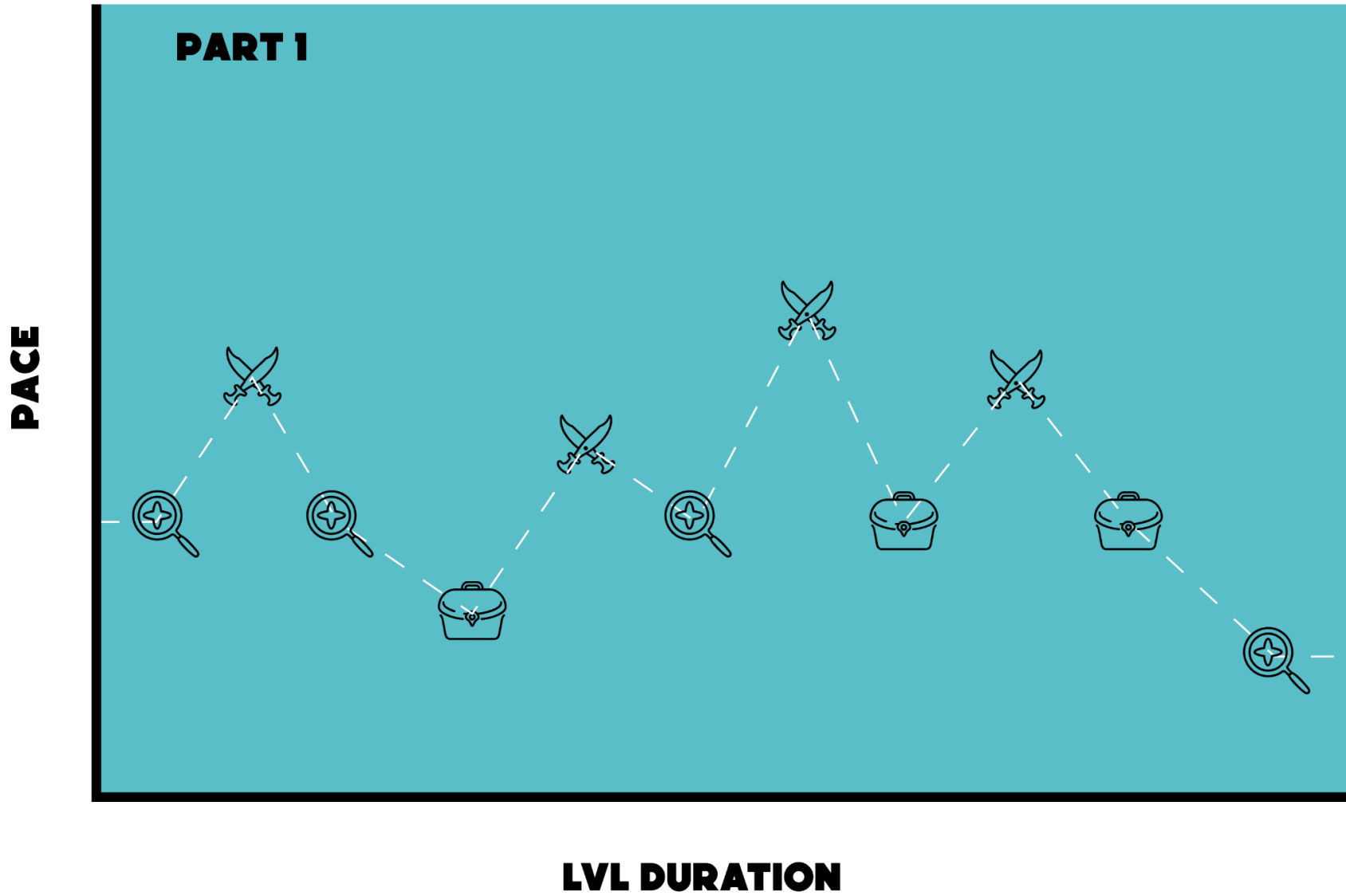

LVL 2

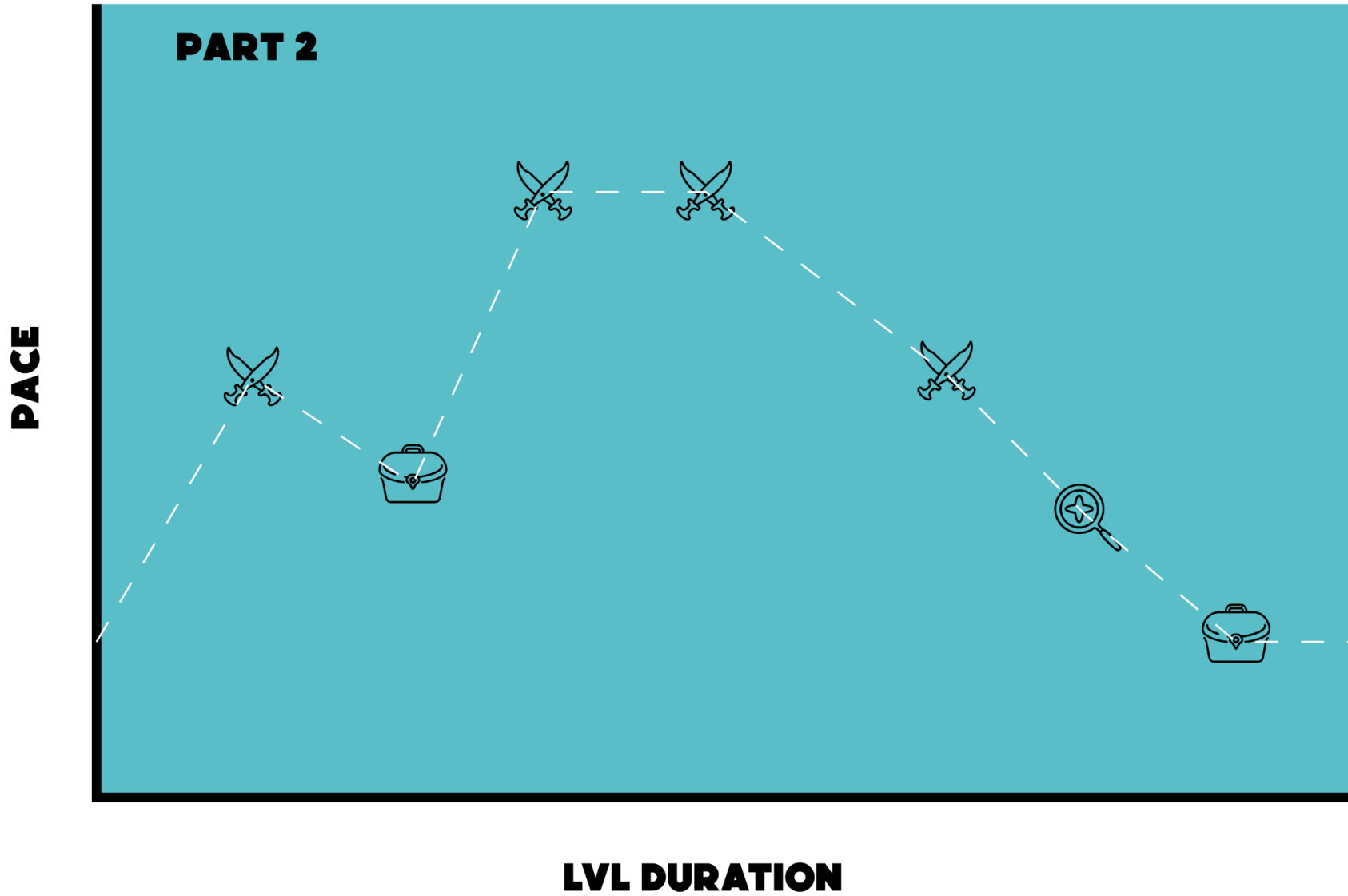

LVL 3

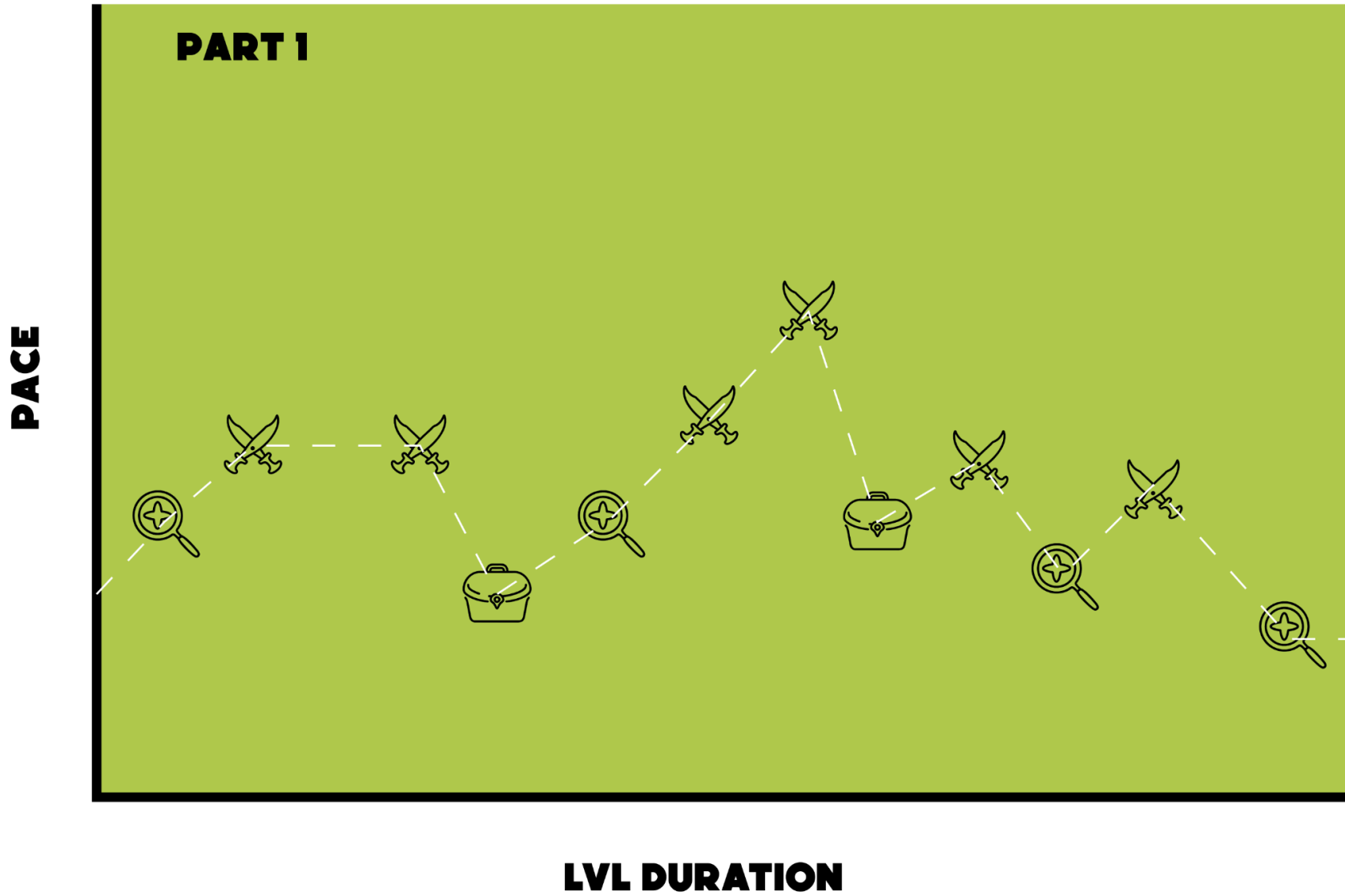

LVL 3

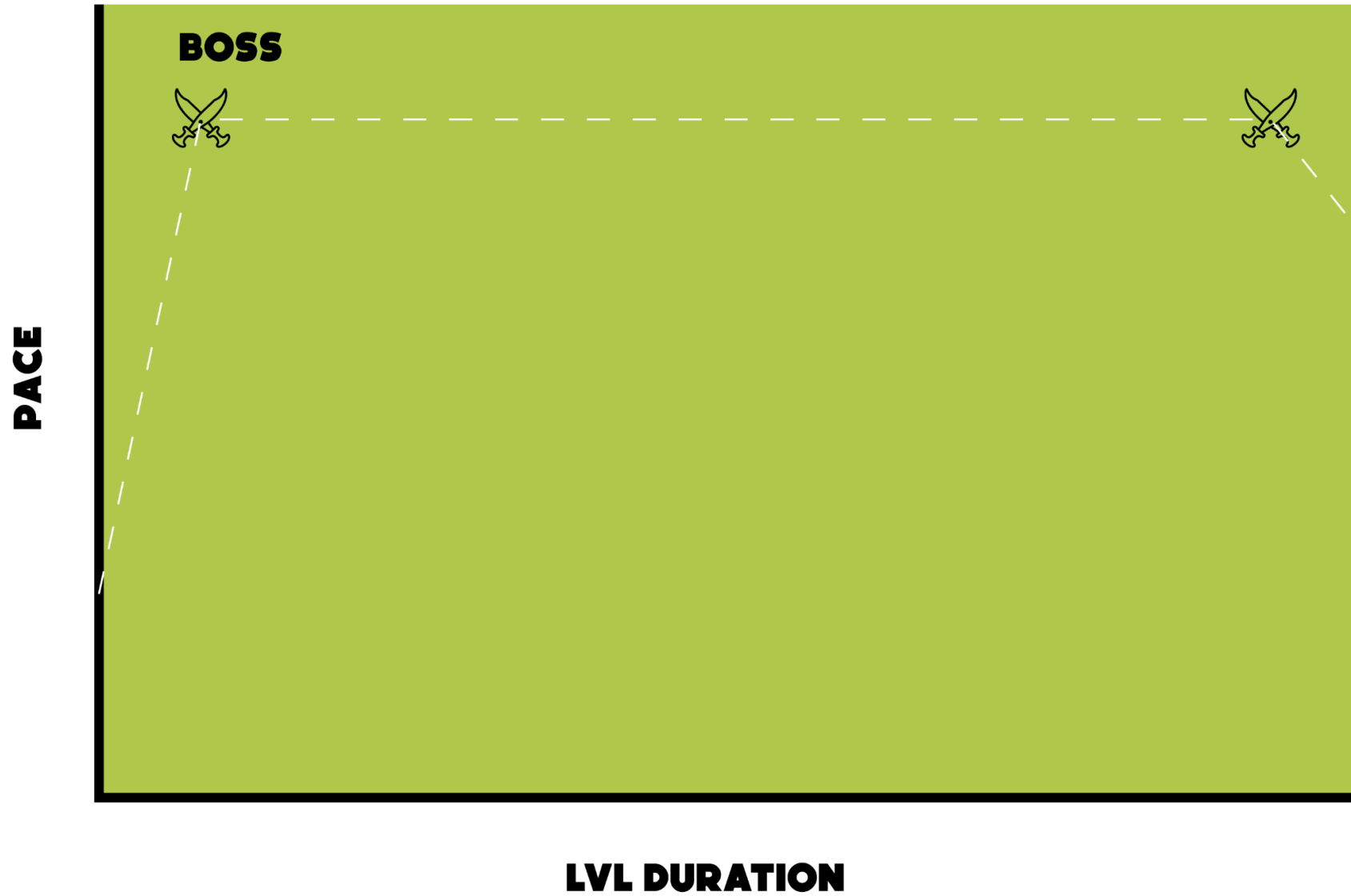

6.2 Base/Spaceship

Structure

The safe zone or base of Alien: Extraction is placed on a spaceship. The player can walk through three different rooms: The teleport room, the upgrade zone, and “Mother”.

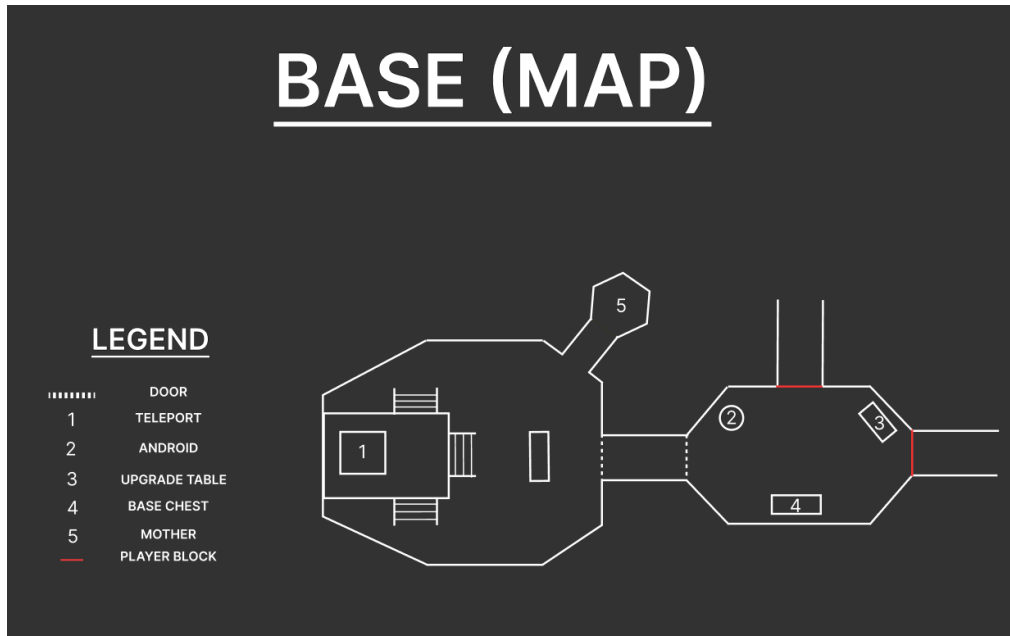

The teleport room is distributed in the following way: On the left is located the teleport over a platform. The player can access this platform going up one of the three stairs located on the left, right and front of the platform. On the right we find a control desk where the teleport parameters are set. From this room you can access the upgrade room or mother.

In the upgrade zone, the player can find three interest points. The first that the player can see is an Android called Caius (2), that will help the player to craft all he needs to survive outside the ship. Another important interest point is the upgrade table (3), where the player can upgrade his weapon. Finally in this room the player can find some boxes and one of them, the most accessible, allows the player to save objects that he doesn't want to lose in case he dies (4). Additionally, this room has two doors that the player isn't authorized to pass. From this room he only has access to the teleport room.

The last room is “Mother” (5), this room locates the AI that controls the spaceship. The player can't do anything there, but it is interesting to see.

Map Elements

In the base, you can find 5 important elements:

1. **Teleport:** the player uses it to travel to the levels.
2. **Caius:** an android that will help the player to prepare for the exploration.
3. **Upgrade table:** a table where the player can upgrade his equipment.
4. **Base chest:** a chest where the player can save materials that he doesn't want to lose.
5. **Mother:** the AI that controls the ship.

Flow

Every time the player dies or has been extracted successfully he respawn here. If the player dies he will appear in the upgrade room where, as it is mentioned early, the player can upgrade or craft your equipment with the materials that he has. Once the player is fully prepared he goes to the teleport room, set where he wants to teleport and uses it to go to the level desired.

If he has been extracted, he will appear in the teleport room, then the player can teleport again to the levels, or go to the upgrade room, to prepare himself or save important items that he doesn't want to lose in case he dies.

6.3 Level 1 - The Warehouse

Structure

The Warehouse is the first level of the game. It is divided into four zones: the tutorial, the warehouse, the burnt room and the “backyard”.



The first zone is the tutorial, where the player will learn all the actions that he can do, this zone will only be accessible the first time you enter level 1.

The zone next to the tutorial is the warehouse, and it is only one room. As is indicated in the name this zone looks like a warehouse. The space is separated by typical warehouse racks, forming a little labyrinth. In this room the player will find 2 chests that contain important materials to upgrade your equipment. Also in this room he can find a mecha that people there used to move boxes, but is not usable. Finally in this room, the player can find an access key that will let him access block zones. From here the player can go to the burnt room.

The next zone is the burnt room, and also is only one room. This room is practically empty and acts like a control zone, because from here, the player can access three different rooms. One of those rooms will be locked, and the only way to unlock it is by opening from the other side.

The last zone is the backyard, divided into 7 rooms. This zone is the first to have traps and enemies. There are two types of rooms: one has metal walkways with metallic boxes below them, the other are normal “empty” sci-fi rooms. Also in this zone you can find Little H.R Giger formations. At the end of the zone is located the door that lets the player travel to level 2. This zone counts with 2 chests, 4 traps, 2 upgrade items and three extraction points.

Map Elements

In the level are 6 remarkable types of elements:

1. **Chests:** Marked at the map as white rectangles. Inside them the player can find materials to upgrade his equipment if he survives.
2. **Traps:** Marked at the map as crosses. This map have two traps:
 - The first one is located in a hallway. Basically in the middle of the hallway there are broken cables that throw an electric shock every few seconds. In total there are four cables.
 - The second one is an ambush trap. When the player grabs the upgrade element located in the secret room, a facehugger appears behind him.
3. **Enemy spawner:** Marked at the map as circles. On every point can appear 1 or 2 enemies, principally facehuggers and droners, only one spitter.
4. **Upgrade element:** Marked at the map as stars. If the player returns to the base with these points, he can upgrade his weapon.
5. **Keys:** Marked at the map as squares. The player can access blocked doors with the same color of the key.
6. **Extraction points:** Locations where the player can return to the base. Every time the player enters the level, one of the locations is selected and only that is active.

Flow

(Only the first time) The first zone and room of level 1 is the tutorial room. In this room the player will learn all the actions that he needs for the adventure. First he will learn how to move and that he can move in any direction. Once he surpasses the first barriers, the player will find the first enemy a facehugger, and to defeat him he will have to shoot. Once the player kills the enemy, he will find another block, with an enemy behind it, here he will be encouraged to use a grenade, to learn to throw items. Behind these barriers will be an inevitable acid puddle, to make him lose life and make him use a heal. After this inevitable lake, there will be another puddle, but this puddle will be avoidable using the dash. Finally there is a bigger space, where the player will be forced to fight facehuggers, with the objective to teach him how his abilities work.

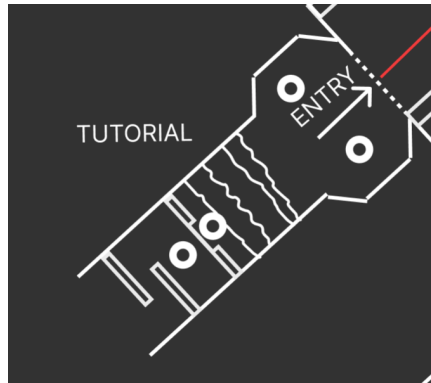

If the tutorial is completed, the player will have access to the warehouse, where the player will have the first contact with the real experience of the game. If the player decides to explore the room, he will find some interesting rewards, like loot chest or an access key, that will be useful later on. From this room, the player has access only to the burnt room.

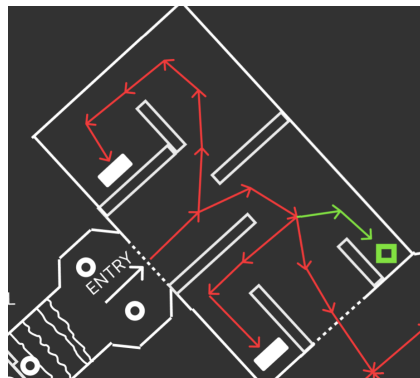

The next room to the warehouse is the burnt room. This room acts like a safe space, where the player can decide where to go, left, to room 5 or right, to room 1. This room also has a blocked door (marked with orange in the map), which only opens from the other side, from room 3, but if the player has opened it in that run, or a previous run, that door will be unlocked and can be used like a shortcut.

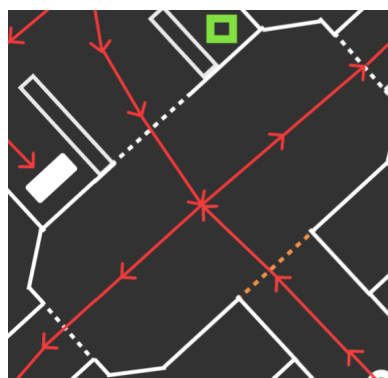

If the player decides to go to room 1, he will find the first enemy out of the tutorial, a Drone spawn. If the player has picked the green access card, he will find in this room a secret path,

where a loot chest awaits at the end. From this room you can access room 2 and the burnt room.

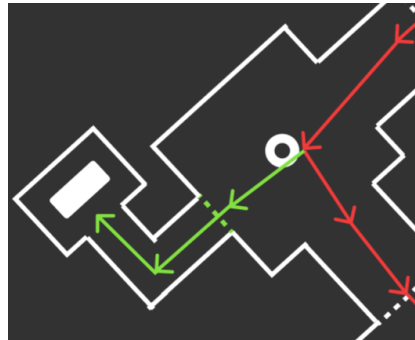

If the next player destination is room 2, he will find a facehugger waiting at the center of the room ready to attack him. Also in this room, a drone will be waiting for the player inside a wall that will jump out once the player enters the room. If the player defeats all the enemies in this room, he will have access to one of the extraction points (if it is the one randomly chosen). From here, the player can return to room 1 or advance to room 3 or the hallway that leads to room 4.

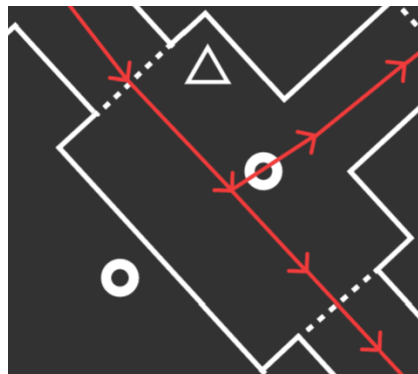

If the player advances to room 3, he will find 2 facehugger spawn and 1 drone spawn ready to fight. Like in the other room, if the player defeats all the enemies in the room, the extraction point will be able to be used (if it is the one randomly chosen). From this room, you can access the burnt room, opening the door that was blocked because, as was said before, is blocked only from one side, making a shortcut to room 3. Also you can go to room 4 or go back to room 2.

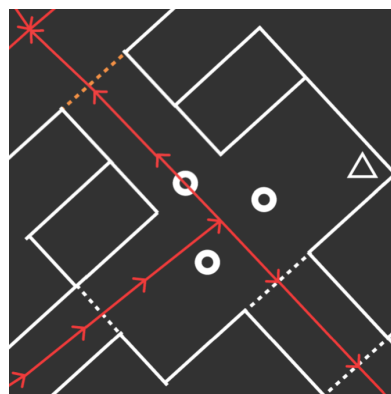

Lights

Directional Light

- Color RGB (0, 0, 35)
- Intensity 1
- Rotation
 - Vector3(5.43,-26.53,-50)

Cars Lights

- Point Light
 - Color RGB(197, 47, 47)
 - Intensity 1
 - Range 0.1
 - Number of lights: 3
 - Positions
 - Vector3(158.279645, 18.7875405, -248.173451)
 - Vector3(286.146879, 18.7875405, -241.338444)
 - Vector3(262.386799, 18.7875405, -139.024568)

Chests Lights

- Point Light
 - Color RGB(166, 231, 138)
 - Intensity 0.5
 - Range 0.1
 - Number of lights: 4
 - Positions
 - Vector3(277.23155, 5.6499999, -59.8864436)
 - Vector3(132.655692, 5.6499999, -226.258755)
 - Vector3(79.7728062, 5.8699999, 129.687512)
 - Vector3(810.531998, 5.7390172, 269.553065)

Beacons Lights

- Point Light
 - Color RGB(28, 152, 40)
 - Intensity 0.66
 - Range 0.3
 - Number of lights: 3
 - Positions
 - Vector3(600.895834, 13.4514183, 72.6272225)
 - Vector3(308.095789, 13.4514183, 176.645982)
 - Vector3(1009.32064, 13.4514183, -120.263159)

6.4 Level 2 - The Lab

Structure

The second level of our game is mainly based on a recently abandoned laboratory that was experimenting with alien organisms which have now been released and have completely invaded the facility.

The level is divided into two zones and an intersection that serves as a separation between them. The **first zone** or area is called Bio-mechanical facilities and is divided between multiple rooms and corridors, starting with a specimen hibernation room (the largest room in this first zone), followed by floating platform corridors that lead in four directions: a small security room, a dead-end walkway, the generator room - which continues to a small hidden area to the north - and the intersection of the level.

The **intersection** or Server room simply consists of a large room that transports the player to the next area.

The **second and last zone** of this level, called Corrupted chambers, is characterized by a large room used as an arena and the exit of the level.

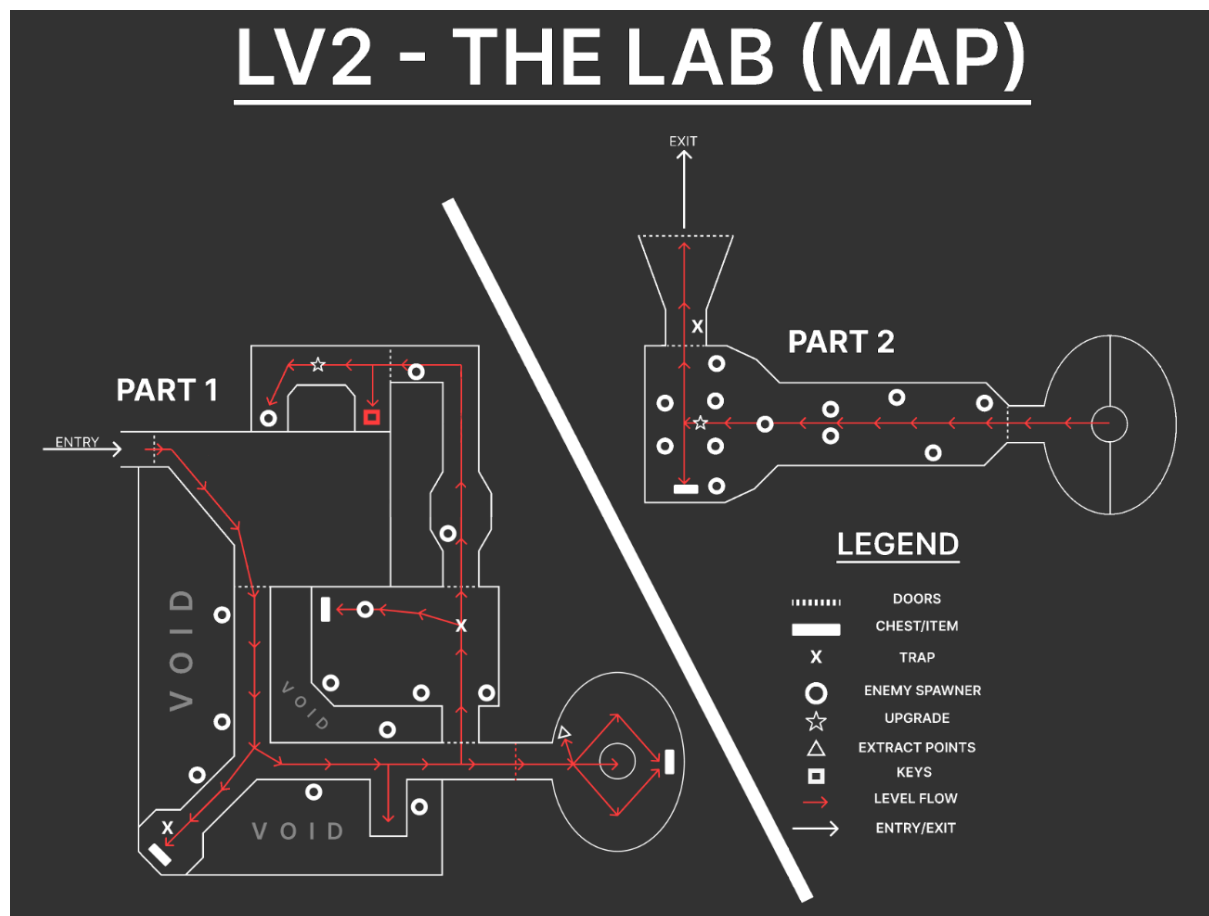

Map elements

1. **Chests:** Chests can be opened without the need for keys or other external objects. They contain a specific pool of items that they can provide (whether resources, consumables or even armor).
2. **Traps:** Small delimited areas of terrain in the form of triggers that apply debuffs to the player or wound him.
As for the traps found in this level, they are as follows:
 - **Electric trap:** trap in the form of wires that will damage the player only the first time it triggers. It is located north of the generator room.
 - **Alien head:** trap which consists of an alien head that has been biologically fused with the wall. It will be activated if the player passes too close to it.
 - **Gas trap:** trap that will generate a small zone which when triggered will explode damaging all the entities in a delimited area.
3. **Enemy spawners:** Fulfill the expected function, they are specific points in which enemies come out or are used as a point of concentration of enemies.
4. **Upgrade element:** Marked at the map as stars. If the player returns to the base with these points, he can upgrade his weapon.
5. **Keys:** Marked at the map as squares. The player can access blocked doors with the same color of the key.
6. **Extraction points:** Locations where the player can return to the base. Every time the player enters the level, one of the locations is selected and only that is active.

Flow

The path that the player will take during the level will be as follows: the player **spawner** is located at the entry of the northwest room of part one (*Bio-mechanical facilities*), which serves as specimen storage. This room is characterized by having five enemy spawners distributed on the sides and corners (to surprise the player) and a smaller room can be spotted to the north of this room through two slits. There will be no enemies in this initial room.

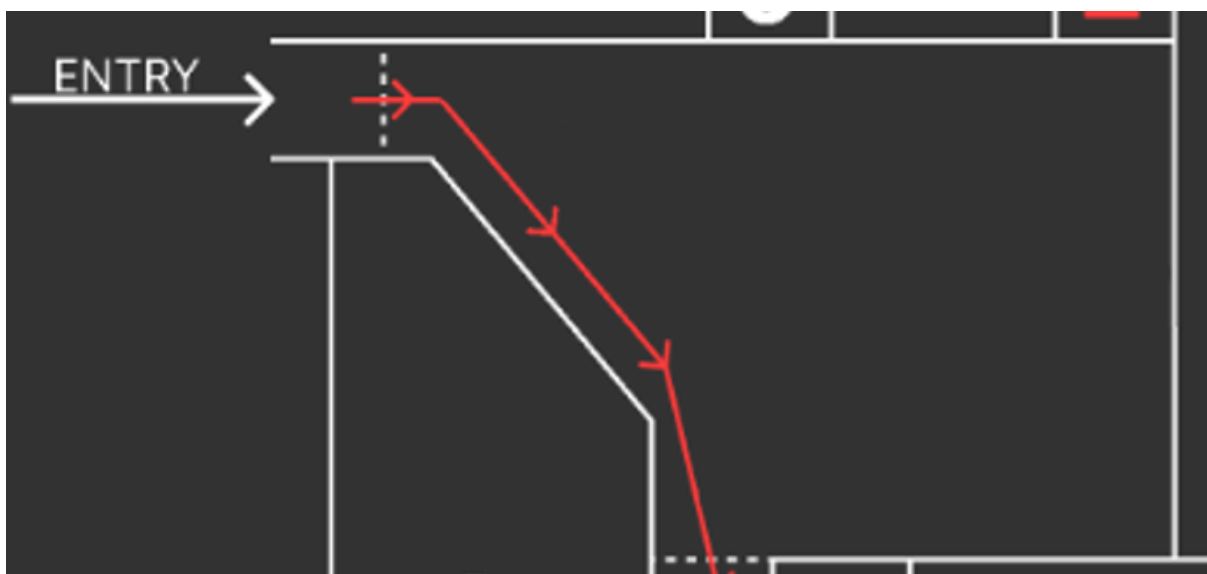

South of the first room the player can advance through some suspended walkways at a very high height, these have spawners of enemies that come out from underneath climbing from them. The first exit of these is a small security room which consists of a trap (*gas trap*) and a chest, leaving this room or continuing along the walkways there is a dead end, a door to the north that leads to the generator room and straight ahead along the walkway to the east is the entrance (closed) of the intersection room. *From top to bottom (on the first photo) then left to right (on the second photo), the enemies that will usually spawn are the following: FH, FH, XS; Then: DX, FH, FH.*

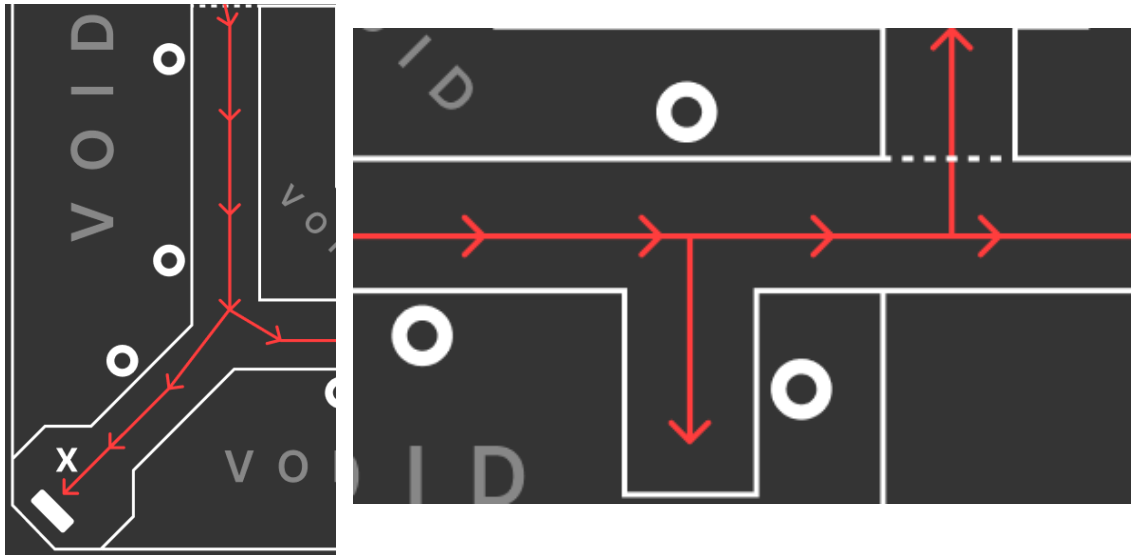

Continuing through the generator room, is a room that is characterized by having several enemy spawners distributed in a similar way to the first room of the level (to the sides and corners), in the center of this room is a trap (Electric Trap), at the back of the room -to the west- is a chest and going straight from the entrance of the room is the exit of this, which leads to a narrow corridor with spawners of enemies that will later come out of the ventilation systems. These corridors end up leading to a small room where there is a single enemy spawner, an upgrade item and an access key. *From top-left to bottom-right (on the first photo) then top to bottom (on the second photo) and also (on the third), the enemies that will usually spawn are the following: XS, FH, FH, DX; Then: DX, FH; Also: DX.*

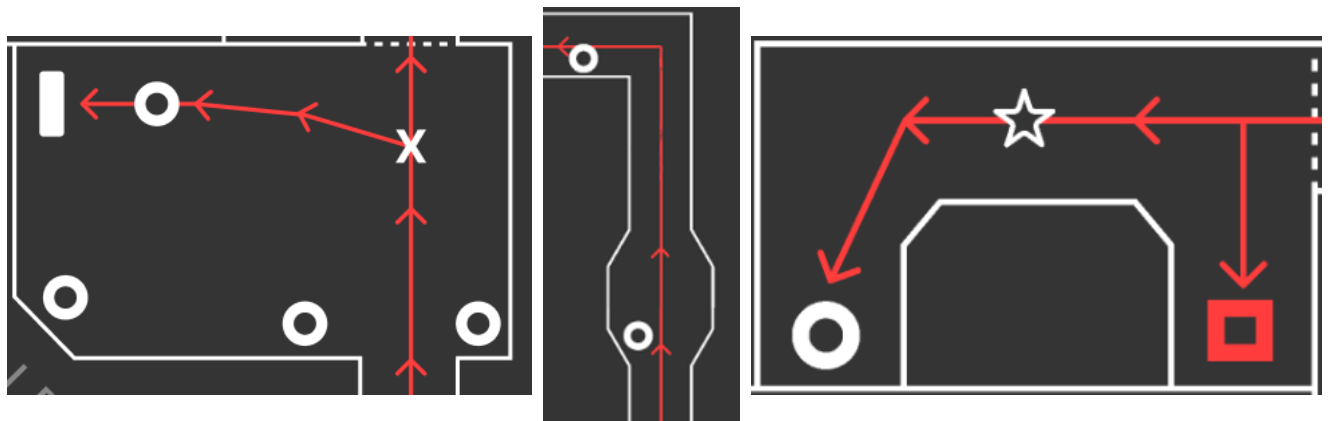

Lights

Prop Lights

- Point Lights
 - Color RGB: (133, 39, 72)
 - Intensity: 0.005
 - Range: 10
 - Number of lights: 26
 - Positions
 - Vector3(-0.1842, -0.3404, -0.8480)
 - Vector3(-2.6169, -0.3471, -0.8809)
 - Vector3(-1.3777, -0.3471, -2.6478)
 - Vector3(-1.9716, -0.3471, 1.8987)
 - Vector3(-1.5859, -0.3471, 0.7140)
 - Vector3(-1.1754, -0.3471, 0.1052)
 - Vector3(-0.3567, -0.3471, 0.5551)
 - Vector3(1.2070, -0.3471, 1.2009)
 - Vector3(-0.3572, -0.3471, 1.5137)
 - Vector3(0.7884, -0.3471, 0.5637)
 - Vector3(2.3885, -0.3471, 1.3543)
 - Vector3(4.2483, -0.3471, 0.9601)
 - Vector3(3.8957, -0.3471, 1.8432)
 - Vector3(4.2514, -0.3471, 3.2468)
 - Vector3(3.3747, -0.3471, 3.4782)
 - Vector3(2.6117, -0.3471, 2.5846)
 - Vector3(3.3541, -0.3471, 2.2302)
 - Vector3(1.4712, -0.3471, 2.8614)
 - Vector3(1.8451, -0.3471, 1.7723)
 - Vector3(2.3249, -0.3471, 3.6782)
 - Vector3(0.4289, -0.3471, 3.4766)
 - Vector3(-0.5065, -0.3471, 3.0659)
 - Vector3(-1.5528, -0.3471, 3.7006)
 - Vector3(-2.8180, -0.3471, 4.4027)
 - Vector3(-1.5848, -0.3471, 2.7827)
 - Vector3(-1.1842, -0.3471, 1.7314)

Traps Lights

- Point Light
 - Color RGB(293, 50, 78)
 - Intensity 0.001
 - Range 10
 - Number of lights: 2
 - Positions
 - Vector3(0.537781239,-0.434538096,1.03087091)
 - Vector3(-2.28418088,-0.379341125,4.148664)

Elevator Lights

- Spot Light
 - Color RGB(0, 61, 95)
 - Intensity 0.001
 - Range 0.1
 - Number of lights: 2
 - Positions
 - Vector3(-1.31239998,-0.241400003,-1.41400003)
 - Vector3(-1.31620002,-0.257999986,-1.41159999)

Reactor Lights

- Spot Light
 - Color RGB(123, 47, 80)
 - Intensity 0.39
 - Range 10
 - Number of lights: 1
 - Position
 - Vector3(0.52700001,-0.282999992,1.89600003)
- Point Light
 - Color RGB(123, 54, 66)
 - Intensity 0.03
 - Range 10
 - Number of lights: 1
 - Position
 - Vector3(0.52700001,-0.135999978,1.89600003)

Directional Light

- Color RGB (0, 0, 35)
- Intensity 1
- Rotation
 - Vector3(350.927246,43.3106804,98.350708)

6.5 Level 3 - The Hatchery

Structure

The third level of our game is characterized by being directly a labyrinthine pre-zone to the final boss room/arena, it is completely corrupted by the alien biomass and its appearance is like that of a huge living being.

The level in question is divided into two main areas: The insides and Queen's demise. The first being the level itself (a fleshy labyrinth) and the second directly the final bossfight arena.

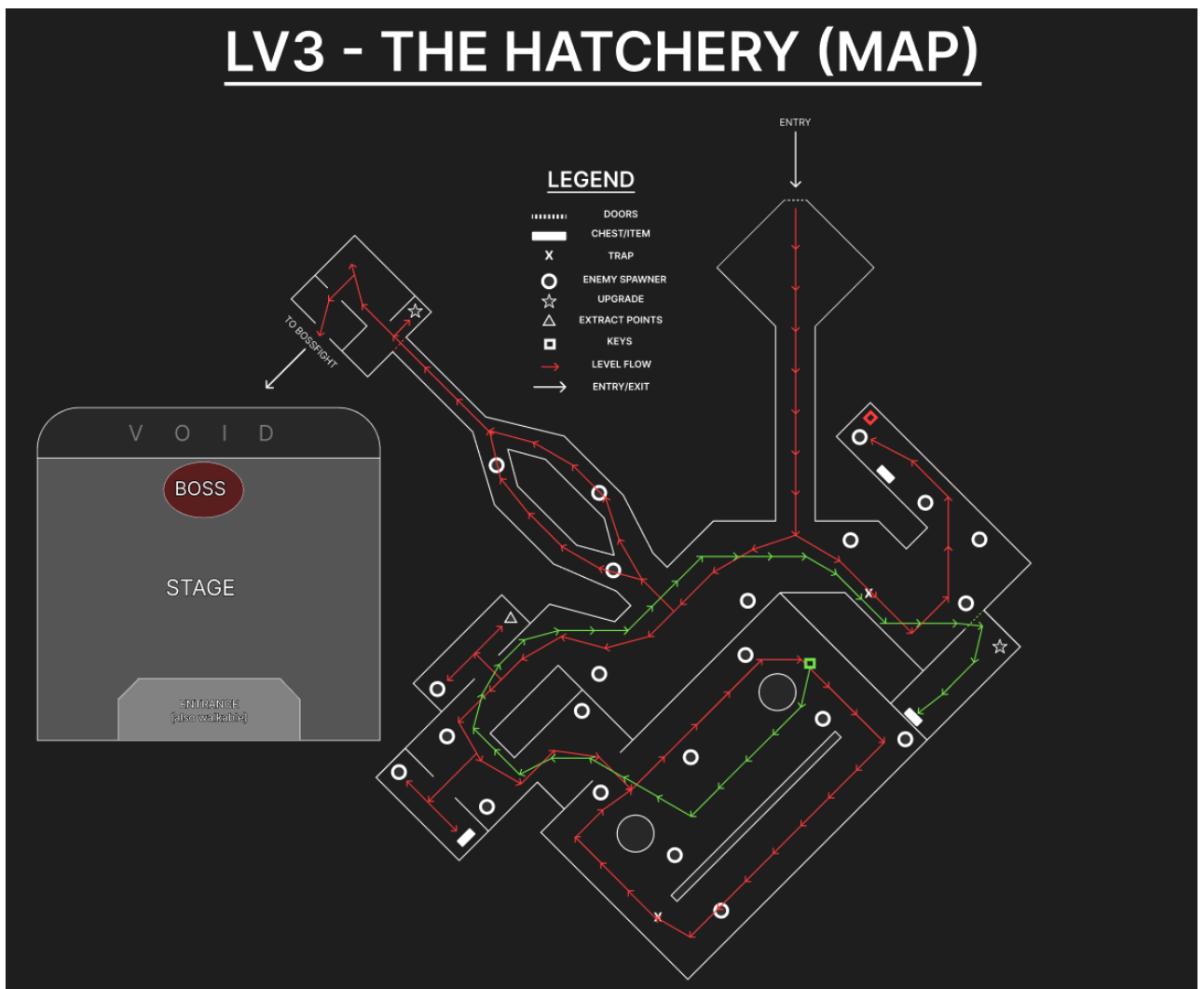

Map elements (same as LEVEL 2)

1. **Entry/Exit:** Simply where both the input and output levels are located.
2. **Chest/Item:** Chests can be opened without the need for keys or other external objects. They contain a specific pool of items that they can provide (whether resources, consumables or even armor).
3. **Trap:** Small delimited areas of terrain in the form of triggers that apply debuffs to the player or wound him.

As for the traps found in this level, they are as follows:

- **Bone bear trap:** Trap in the form of a big jaw, if the player steps on it or near it will take damage.
 - **Fleshy quicksand:** Trap which consists of a small well of clotted blood that once stepped on will significantly slow the player down.
4. **Enemy spawners:** Fulfill the expected function, they are specific points in which enemies come out or are used as a point of concentration of enemies.
 5. **Upgrade:** It is a special item that is located 2 times per level.
 6. **Map element:** These map elements will be extraction points for the player. With the exception of the one in the first room of the level, which is an access card.

Flow

The player's journey begins in a large diamond-shaped room (where the player **spawn** is located by the entry door) followed by a long corridor that introduces the setting and gives a sense of danger.

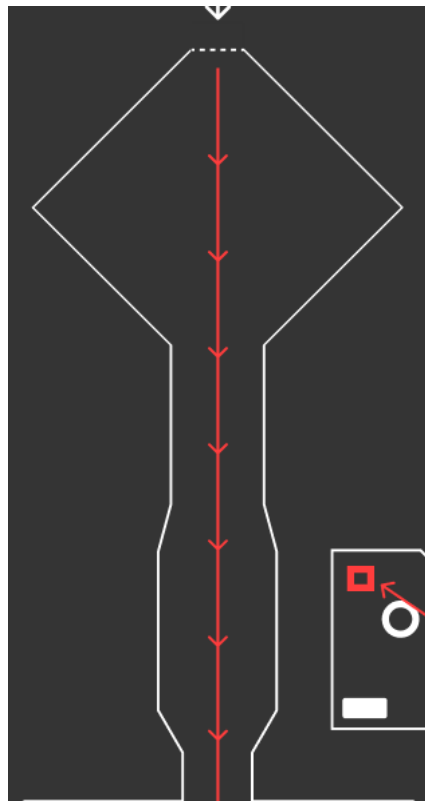

After this first corridor, the player will find another one in the form of a snake that connects with all the rooms of the level, which will be the link during the whole tour. In this corridor there are also different enemy spawners located on the sides and near the walls to surprise the player. *From left to right (on the first photo, then the second photo & the third), DX, FH; Then: XS; and then: FH, DX, XS.*

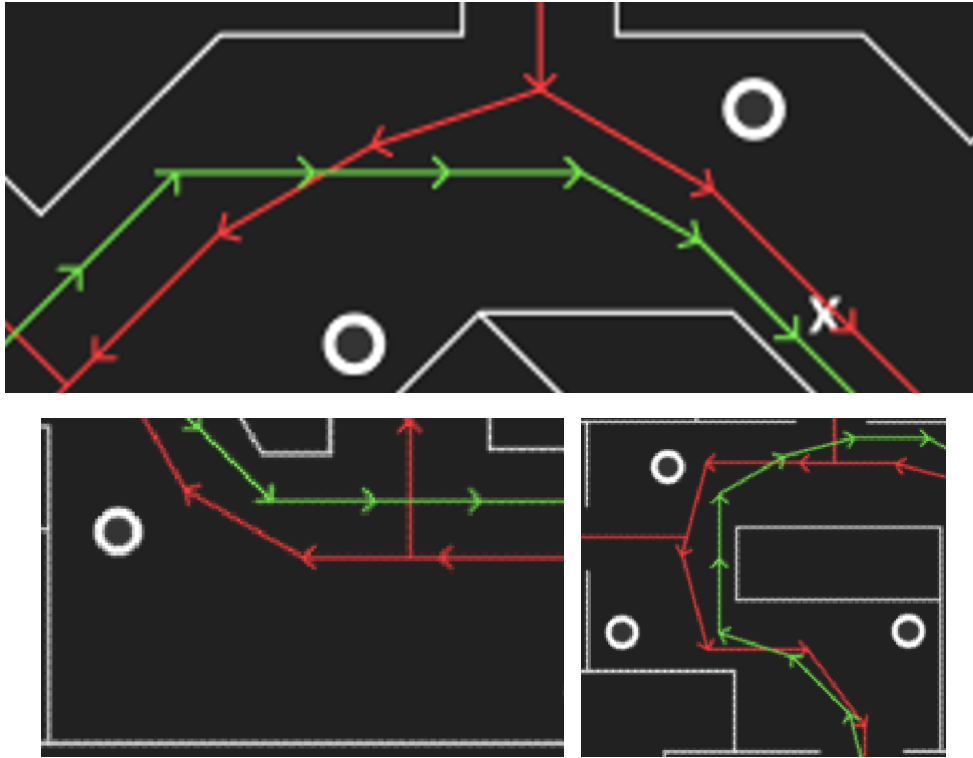

Starting from right to left of the map (from the corridor described above) you will find a room with a trap at the entrance (Bone bear trap), this room has a locked door (which opens with a key further ahead) and then continues down a corridor that connects to a small room containing a chest and a key (this key does not open the locked door within this rooms). *From left to right (on the first photo, then the second photo), DX, FH, FH; Then: XS, FH.*

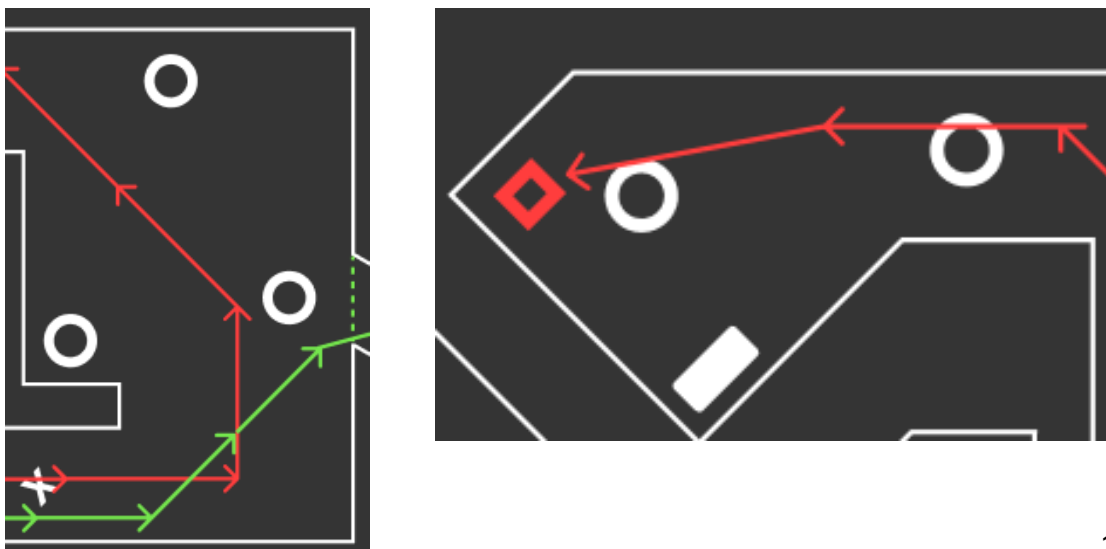

Continuing down the main corridor (ignoring the one that splits in two and going straight ahead) the player encounters multiple nooks and crannies and tiny rooms: the first is a narrow one that has two directions, an extraction beacon to the east and an enemy to the north. The next room (if you continue down the main corridor, naturally) is another small room but this one is less narrow than the previous one and consists of another enemy to the north and a chest to the south. *From left to right (on the first photo, then the second photo), DX; Then: DX.*

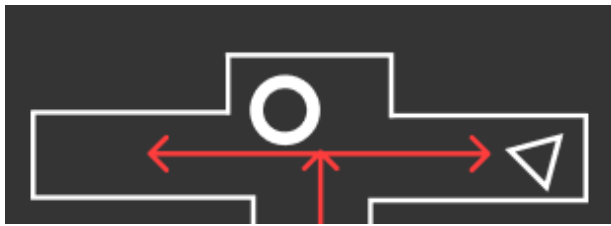

Once the player reaches the end of the corridor, he finds the largest room of the level, which is composed of 7 enemy spawners, two columns at the ends, a dividing wall at the bottom, a key and a trap at the west (Fleshy quicksand). *From left to right, on the first photo: FH, DX, XS, FH, FH, DX.*

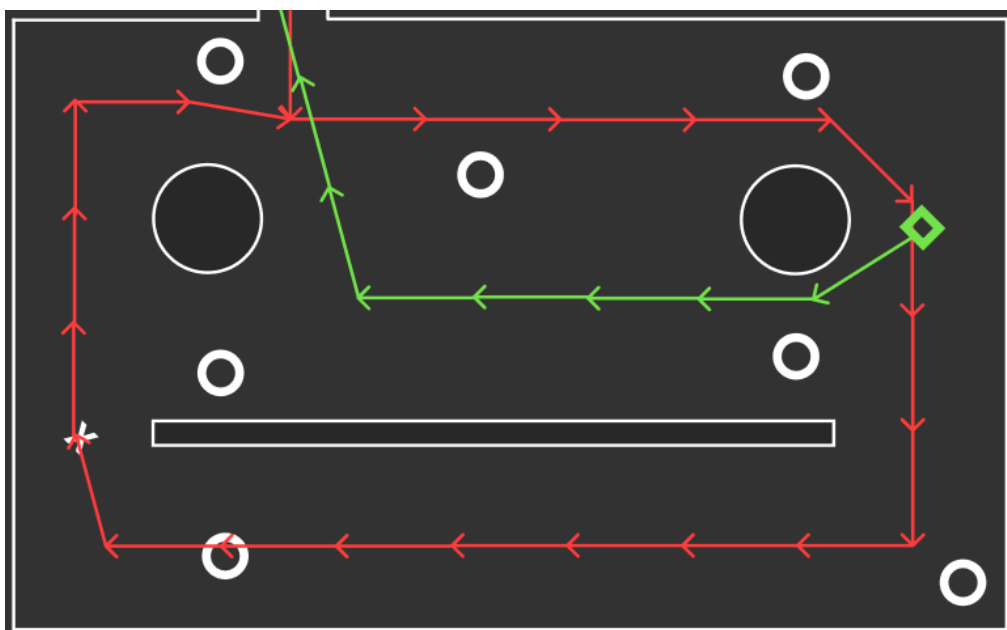

If the player decides to take the key, he/she must go through the large snake hallway again and retrace his/her steps to the room (this itinerary is marked on the map with green arrows) that contains a locked door. using the key will open it and reveal a small hallway with an upgrade at the beginning and a chest at the end. It is worth noting that from the large room you can see the chest of this corridor.

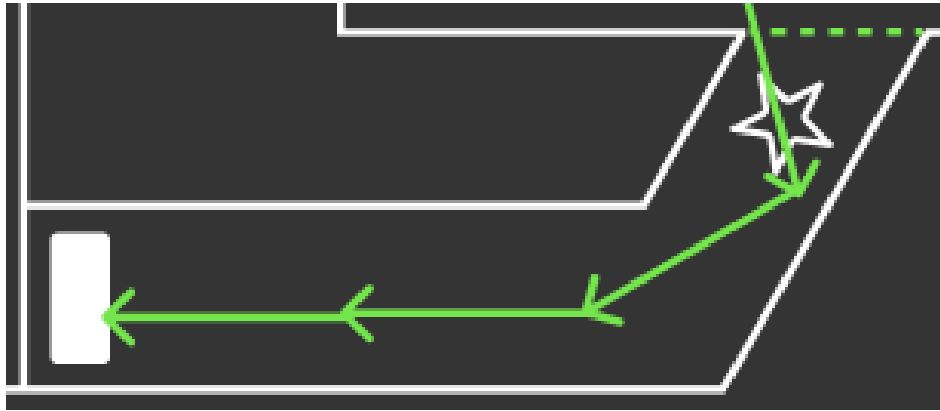

Returning to the corridor that splits in two in the middle of the level, it consists, as mentioned above, of a bifurcation in two directions: in one there are two enemy spawners and in the other only one. Continuing on, the player encounters a locked door (which is opened with the key located next to the chest, in one of the first rooms). Once opened, the player will find an upgrade to the north and if he continues through the small rooms he/she will reach the bossfight room. *From left to right on the first photo: DX, FH, XS.*

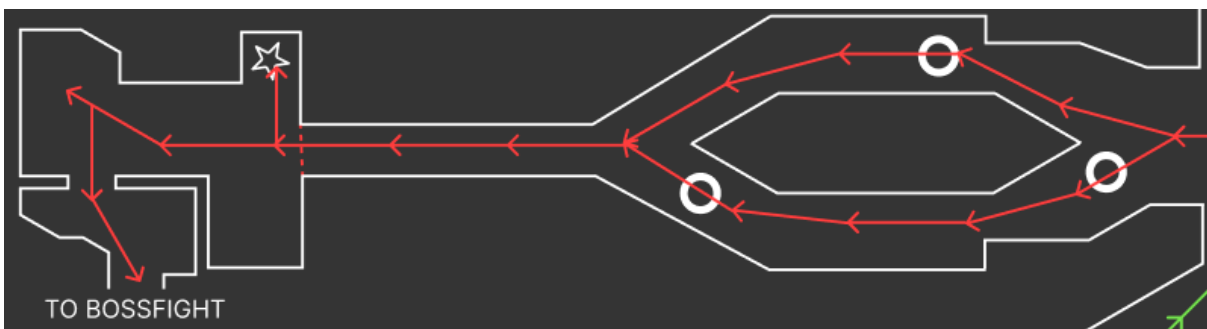

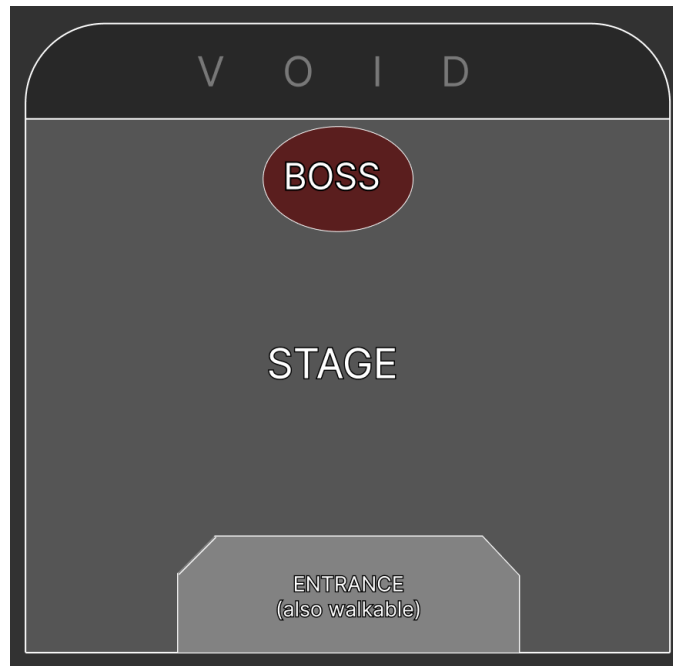

Finally, the bossfight arena consists of a large square room with a small raised surface (in which is the entrance) and the rest is a large stage in which to fight with the boss and at the end of the room there is an empty area or void, the queen will be chained by a structure suspended in this void. This level will have a **fog shader** in its entirety to deepen the darkness of the environment and aesthetics.

6.6 Enemy encounters

- Tutorial:

There will be a group of enemies at the end of the tutorial. When the player gets near enough (just before they enter the camera range), the player movement is disabled, and a small camera pan guides the player's view to focus the idle enemies, and then come back to the player's view.

- Enemies:

In each enemy spawn marked on the map 1-2 enemies will appear. Each spawn has a specific enemy defined. There are some specific spawns in which the rarity of the enemy will also be defined, appearing an enemy of rare or epic class regardless of its probability.

- BOSS:

The player enters the boss' room. The camera is placed in front of the player as he enters the room until he stops past the door. Then, the camera is placed in front of the chained queen, pointing at her. The queen seeing the player triggers an animation of it freeing herself from the chains. Once it has freed itself it screams, then commencing the fight.

6.7 Chest Items

Level 1 - The Warehouse:



1. Common Armor
2. Rare Tail tip
3. Rare Alien claw
4. Common Defensive Chip

Level 2 - The Lab:

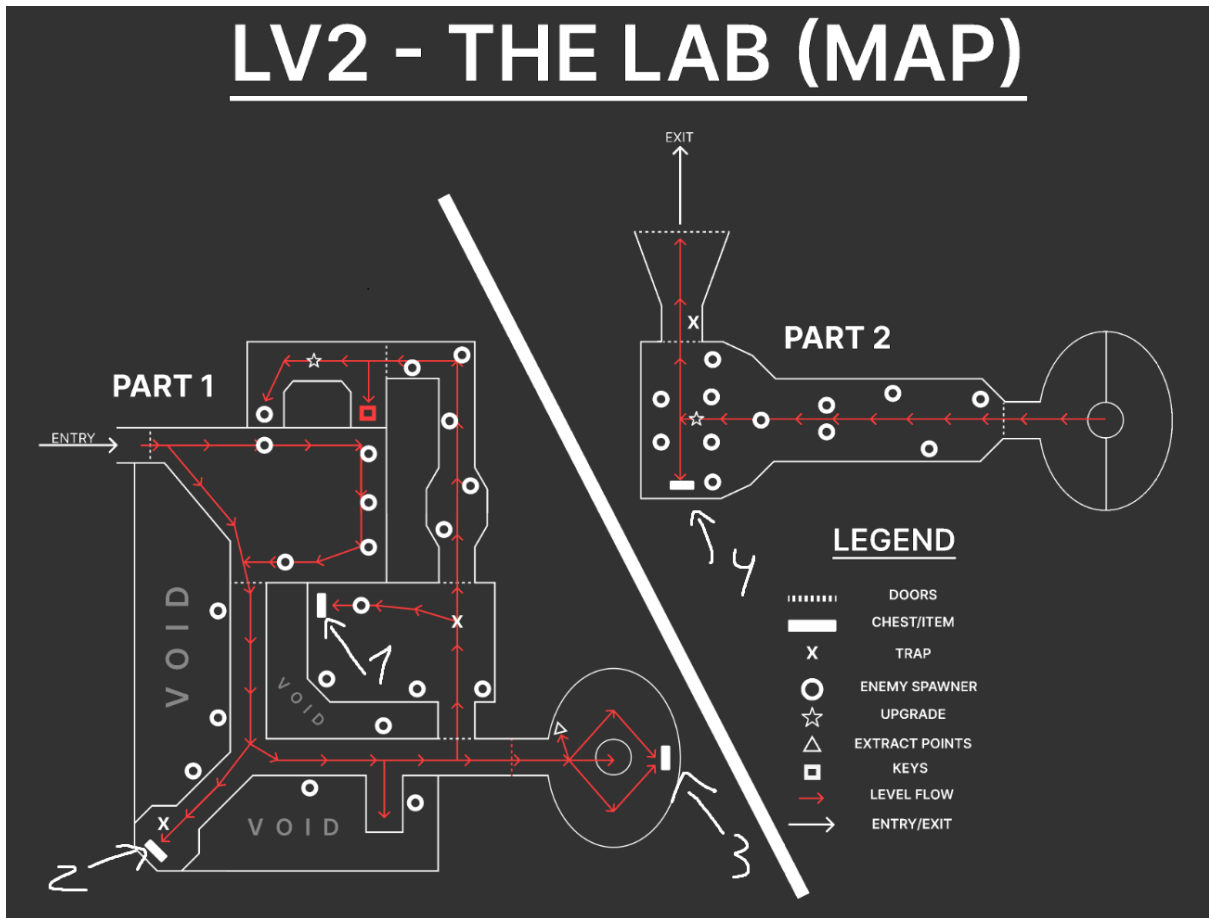

1. Common Alien acid vesicle
2. Rare Alien acid vesicle
3. Common Offensive chip
4. Epic Alien aluminium bone

Level 3 - The hatchery:

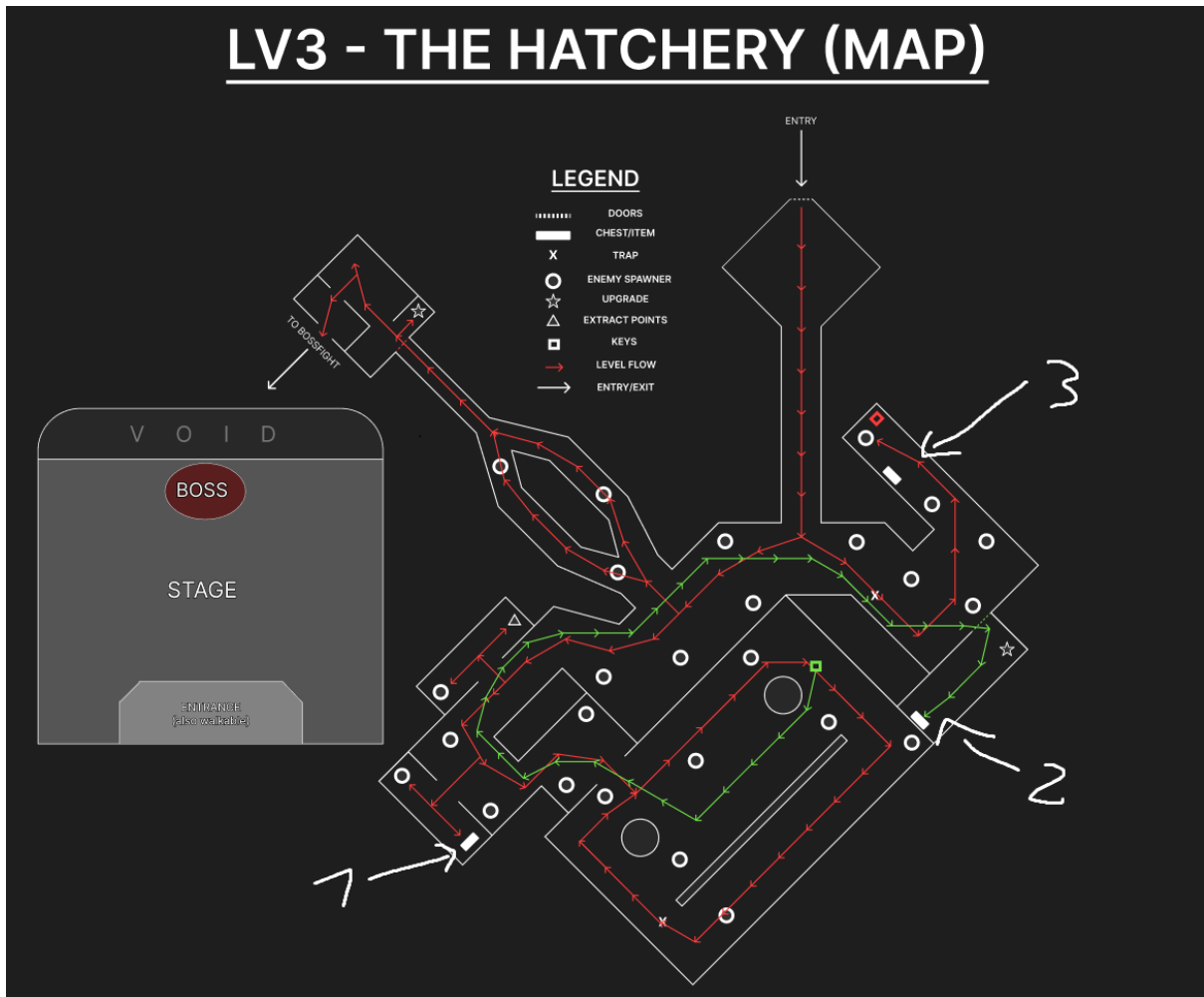

1. Epic Alien exocranium
2. Epic Defensive chip
3. Rare Armor

6.8 Asset list

Base props

- **Teleport:** This teleport is used to travel across the levels. Located at the teleport room. This teleport is formed by three circumferences, one at the top, and the other two at the sides. At the bottom there is a circumference that emits a blue light. Once the teleport is used, it makes a teleportation sound. The general color of the teleport is white, with cream details. Also the teleport is not very big, necessary for the player to enter. (Not as detailed as in the pictures).



- **“Mother” chair:** This chair is located in the room called “Mother”. The aspect of this one is like a futuristic armchair. Also has a computer connected to the chair. To be more specific, this chair is equal to the one that appears in the movies of Alien.

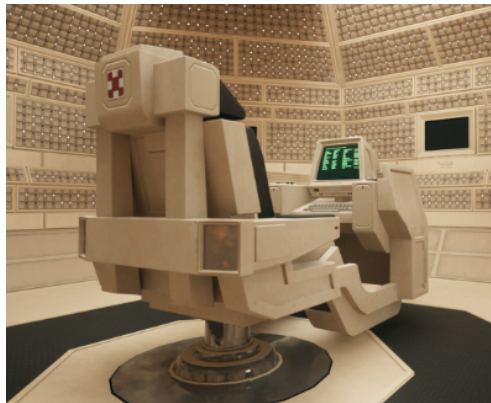

- **Upgrade table:** It is a table for upgrades located in the base/ship. It has a mechanical arm that should be able to move (it should have a small movement animation). Then the table should have a futuristic look similar to Starfield. On top of this table it would be nice to put a computer or screen where the upgrades will be projected (not literally, just with a drawing of a weapon). Also on the table, it would be nice if there were various materials like in Starfield (cables, metal objects, chargers, batteries...). As for the size, it doesn't have to be very big either, we imagine it to be

more compact, so that a human can reach any part of the table without having to make an effort. Also so that the arm can reach everywhere.



- **Metal boxes:** Used to store the necessary material for the journeys and expeditions. These are near the base chest. They are cubes, with the borders a little bit bigger than the rest of the box. They are gray with blue details at the borders.



- **Base chest:** In this chest, the player saves all the materials that he doesn't want to lose. Similar to the chests of the levels, with sharp shaped edges, with a sci-fi style. Also the color is white with green details. When the chest is opened, it makes a sound. Located at the upgrade room.



- **Selection screens:** Before the teleport, there are two screens attached to the ground where the player will choose the level and the weapon (symbolic), the screens are blue with some data and cover all the surface of the altar.



- **Ramps:** These ramps are used to access the teleport. Have the same metallic style as the platform. And are located around the teleport platform.

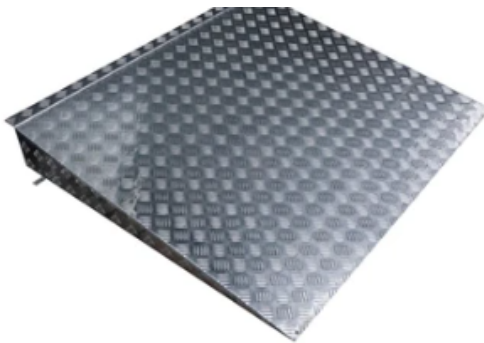

- **Teleport platform:** This rectangular platform holds the teleport (See [map of base](#) and the blockout to know the size). Is metallic and has gray bars at the sides, except for the zones where the stairs are located.

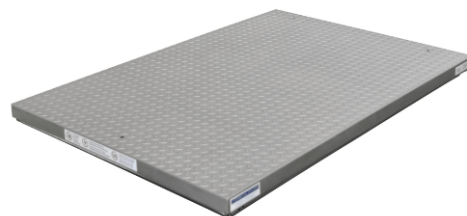
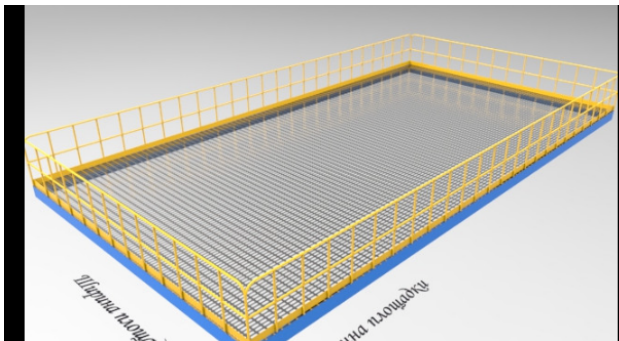

Base infrastructure

- **General Description:** The general aesthetic of the base infrastructurally has to be an active spaceship environment. All has to be very clean and futuristic looking. The principal colors that predominate are: light gray, white, blue and green.
- **Floors:**
 - *Teleport room floor:* this floor needs to be mostly white with geometrical black forms that marks a path to follow. The material is like plastic. Is located in the teleport room and the hallways to other zones.

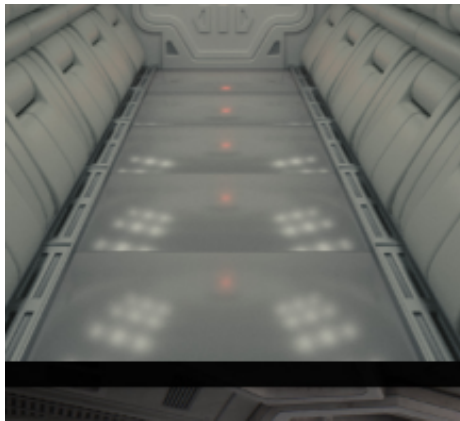
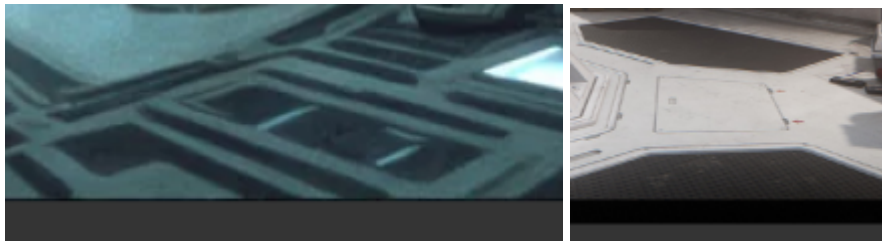

- *Mother Room floor:* this floor is entirely dark gray and has an hexagonal form. There is another hexagon on the floor, smaller and darker than the floor, where the chair will be located.



- **Walls:**

- *Teleport room walls interior:* These walls are smooth, and white but with lines that form geometrical patterns. The bottom of the wall is thicker than the rest of the wall and is of a light gray.



- *“Mother room walls interior:* The walls of this room are special, and are formed by “computers”. Every wall has a screen surrounded by rectangles with yellow points (these points are made with yellow particles that appear and disappear as flicker). Also the room forms an hexagon, so it is imprescindible to make the wall having this in mind. It does not require any animation for the lights to simply put yellow points, the roof is not necessary.



- *Hallway walls:* These walls have an hexagonal form and are white. They are formed by cylinders that make the wall feel padded and have lights at the top like in the next image.

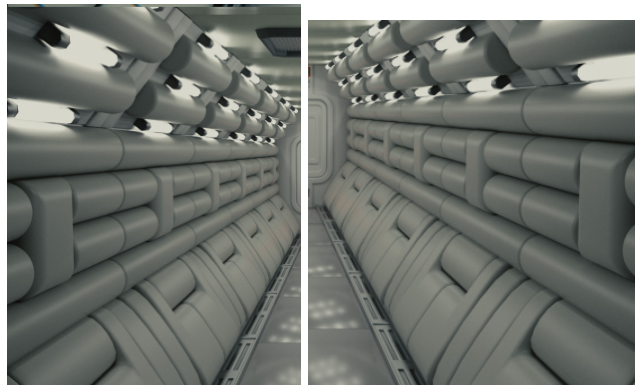

- **Exterior walls:** The exterior of the walls is the same for all the rooms, because they need to look like a spaceship, so all the walls need to be divided in two thinking on the outside. The color is gray and metallic, with some dust details and some lines that makes it a sci-fi effect.



- **Doors:** There are two types of door, the opened door, and the closed doors. The difference between these is the color, the opened door has blue details, while the blocked have red details. For the geometry they have the same, the form is a hexagon, to follow hallway form, also the primordial color is white. Everytime the door opens a particle of pressured air appears where the door opens.



- **Ambient exterior:** The exterior ambient is the surface of the [planet](#). An orange rock surface.

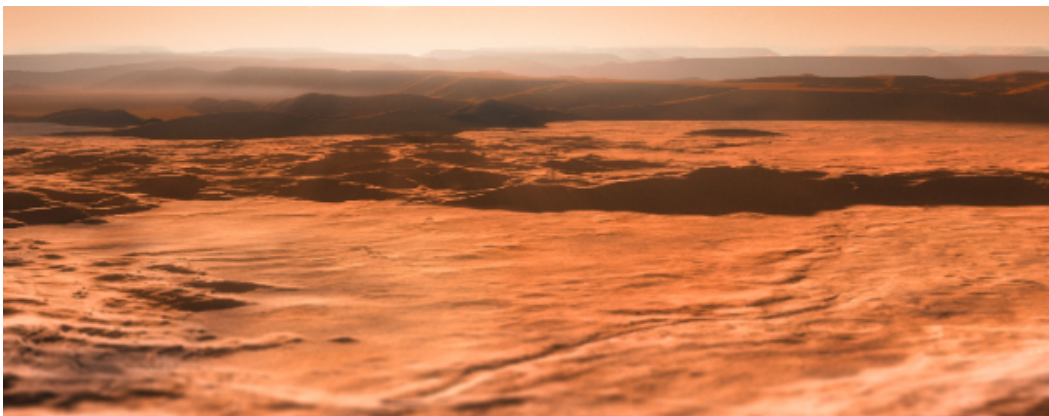



General Lvl Props:

- **Beacon:** This prop is located in all levels, specifically in already defined points (if there is more than one defined point in a level it means that the beacon can spawn in one or another). They will be used as interactables to return to the ship (extraction points). Visually they are like small devices stuck in the ground, with a blinking light.



- **Altar:** This prop is located in all levels, specifically in already defined points. Here the player will get the Alien Core to upgrade his weapons. It is the asset that has a more HR Giger look. In silhouette it resembles a baptismal font, inside it will have the Alien Core, although this should not be included in the model. It should have a lid following the same aesthetics and so that the player can open it.

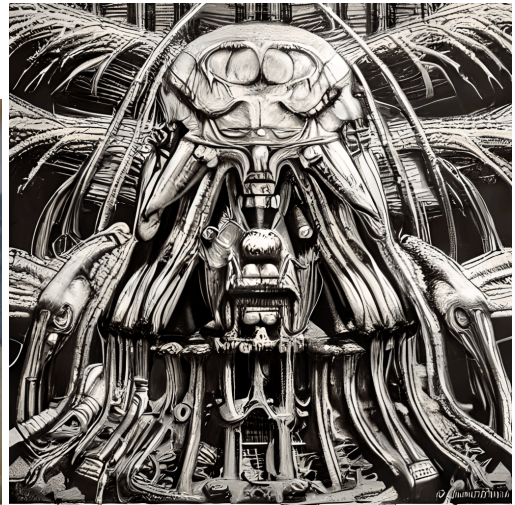

Lvl 1 props

- **Warehouse racks:** These racks are located at the warehouse of the lvl 1. They are taller than the player (4 m approx), and will act like a wall. It will be formed by 3 levels, the base of the levels will be made of wood and the bars that uphold the rack are yellow and metallic. On the levels there are carton boxes.



- **Mecha:** This mecha is located at the warehouse, and was used to transport the materials. It has a similar appearance to a human, with two legs and two arms, but with no head. The seat is located at the middle of the mecha, and has levers to control the extremities. Is yellow, and the seat and levers are black. Now it is unfunctional.

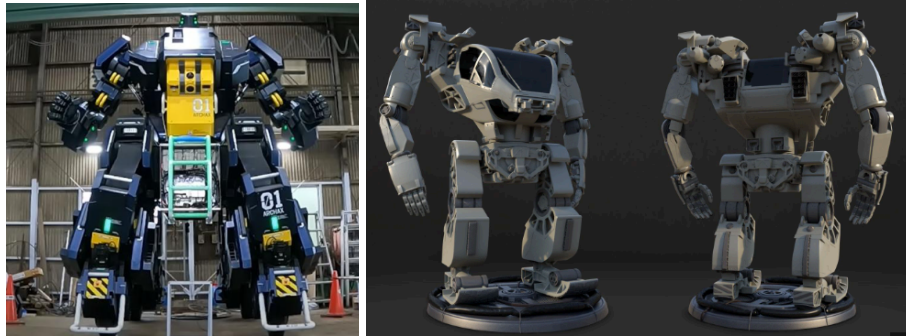

- **Burnt debris:** This is the material that was burned off the warehouse to block the aliens escape to the outside of the planet. Is located in the burnt room. These debris are still on fire, but are not very intense. They emit a sound of things getting burned. A few smoke particles come from this asset.



- **Warehouse material:** In the warehouse a lot of items are used to transport the cases. In this warehouse there are pallet jacks, autonomous trolleys and hydraulic stackers.

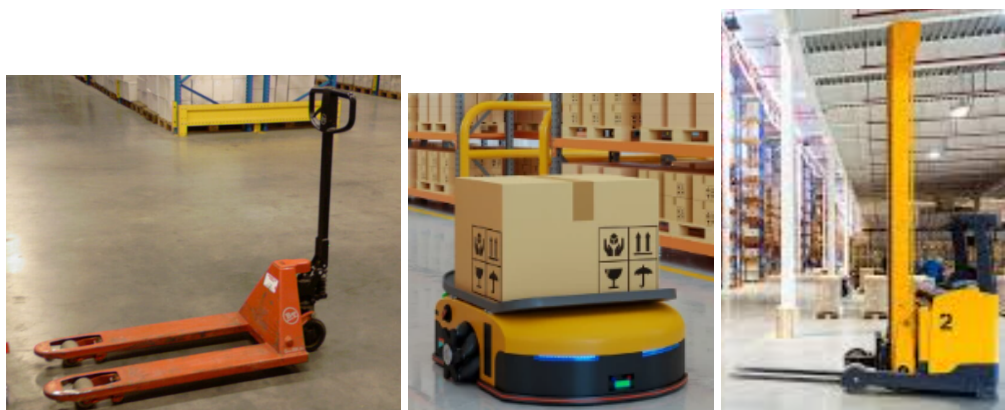

- **Metal containers:** Used to store more confidential material that can't be in the warehouse. These are located in room 3 and 4. They are cuboids, with the borders a little bit bigger than the rest of the box. They are gray with yellow details at the borders.



- **Vents:** These vents help with the air circulation in the warehouse, but the system is broken. There is one for the room minimum and hallway. Their form is square shaped, and are formed by laminates. These are metallic and gray. From inside the vents a white smoke comes out, covering the ground a little.

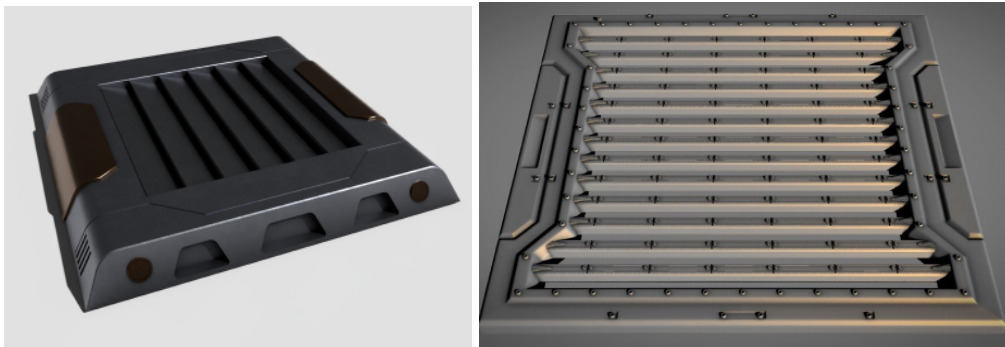

- **Broken cables (electric trap):** These cables are broken and block the way producing a short-circuit. These are located at the hallways to room number 5 and on the hallway between room 5 and the final room going out of the walls. Are two cables the size of the hallway, color black and produce an electric particle, with a sound of static. There is a shock every 2 seconds that lasts 2 seconds (2 seconds rests, 2 seconds shock, 2 seconds rest...). It deals 220 damage and the range is wide like the hallway.

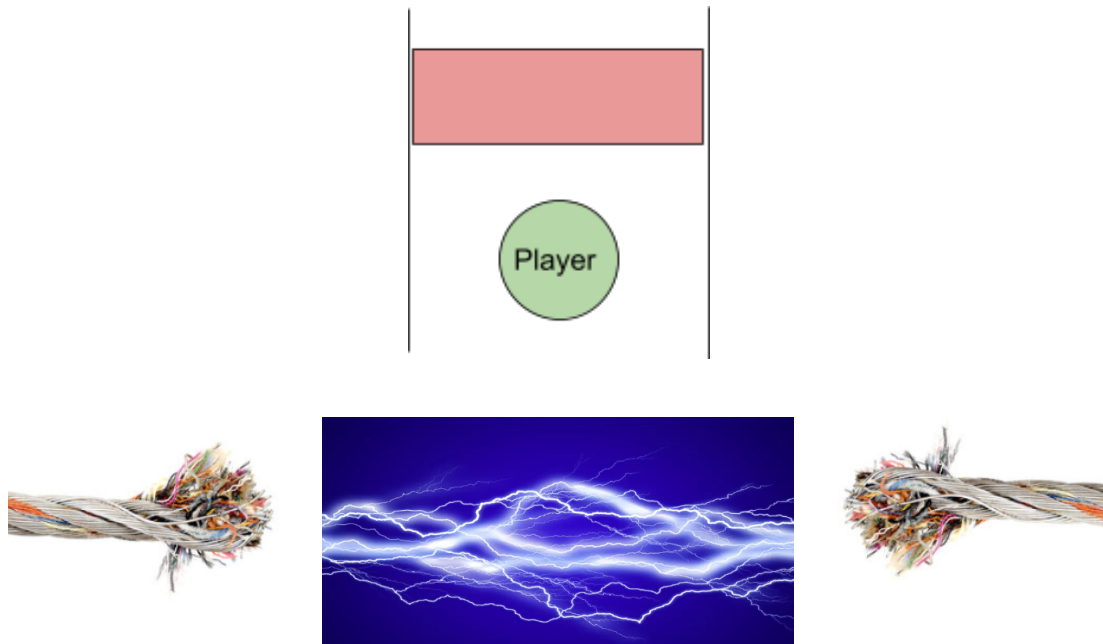

- **Android head:** you can use the iscarriot head for this.
- **Dead body:** Generic dead body person, with scratches and burns (this asset will be used in other areas)



- **Broken holo screen:** Just take the holo screen model and change the texture so it looks like it's crashed.

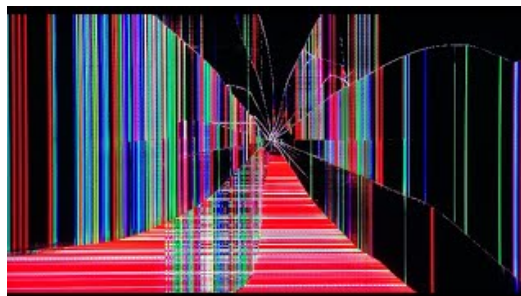

Lvl 1 infrastructure

- **General description:** This level pretends to be a cover for the lab, so it seems like a normal warehouse. The level is divided in three zones: the first zone is the warehouse where white, yellow and brown predominates. The second zone is equal to the first, but it is all burned, so the walls have lost their color and are mostly black. The third zone is an extension of the warehouse, but the walls are smaller and there are some metallic gateways.
- **Floors:**
 - *Warehouse Room floors:* these floors are white and simple, made of rectangular tiles. Also this floor has yellow lines that surround the racks.



- *Burnt Room floor:* This floor is equal to the warehouse, but it needs to have burnt details, like ashes, dust...



- *Back Zone Floor:* These floors are made by squared dark gray tiles, with white thick lines that separate them. Some of these floors have little infected zones, with an H.G Giger. This floor without the infected zones will be used at the tutorial.



- *Getaway floor*: This floor has a specific form, consult it on the [map](#). The floor is metallic and from the same gray of the back zone floor. Also these floor counts with bars to protect the player from falling down.



- *Secret floors*: These floors are light gray, metallic and plain. At the sides of these floors there are low intensity lights that mark the path. Also these paths are very clean because of their lack of use. Remember that these secret hallways are only a little bigger than the player.

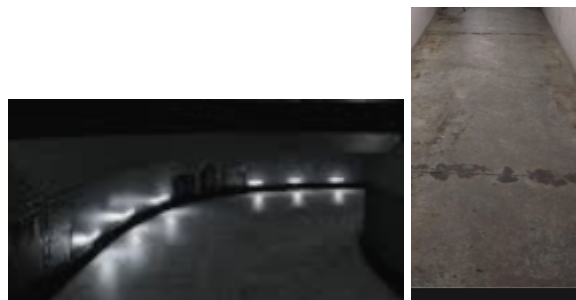

- **Walls:**

- *Warehouse walls*: These walls are tall and white (do only a 3m wall that can be copied above). Also the walls have white crosses formed by metallic beams that stand out a little bit of the wall.



- *Burnt room walls*: The same walls of the warehouse but burned, the beams are rusty and the walls have ashes.



- *Back zone walls:* Dark gray walls with a white cross on the walls. The walls are joined by white columns. Also the bottom of the wall is thicker and a little bit darker.

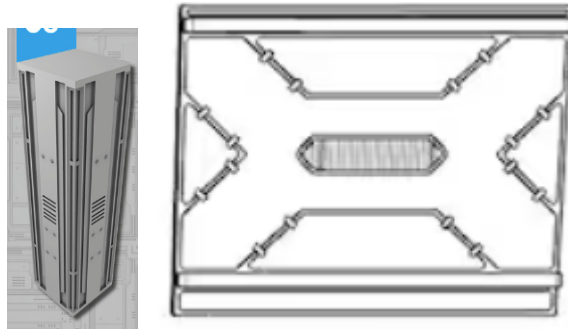

- *Bars wall:* This wall is located at room 6 (look at the blackout to see the dimensions). It has a rectangular hole at the center, where vertical metallic bars are. The aesthetic of the wall is the same as the back zone walls.

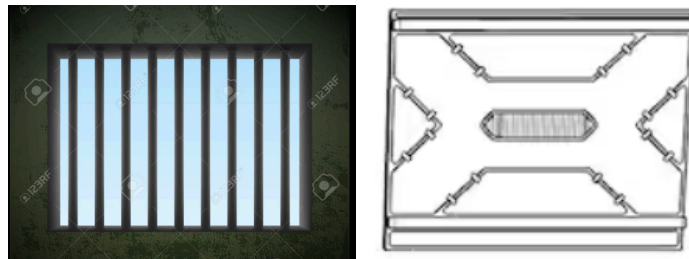

- *Secret Walls:* As the secret floors, these walls are light gray, metallic and plain. In the corners there are small black columns.



- **Doors:**

- *Warehouse doors:* Large big metallic doors with the top edges sharpened, sci-fi style. Their color is yellow. The door opens from the middle to the sides. Also is needed a normal version and a burnt version (where from one side is good, but the other side is burned).



- *Back zone doors:* These doors are metallic with curved top corners. Their color is dark gray and the color of the door frame is white. The door opens from the middle to the sides. Also is needed a normal version and a burnt version (where from one side is good, but the other side is burned). Everytime the door opens a particle of pressured air appears where the door opens.



- *Secret doors:* These doors are the same style as the back zone doors, but smaller and it opens from top to bottom. Everytime the door opens a particle of pressured air appears where the door opens.



- **Ambient exterior:** Level one will have two exterior types, one based on the ship exterior and another on the LVL2 exterior. As the player dives into the level, the exterior colors and texture will darken as shown in the picture below. The idea is that the player is entering a cave, so, as the colors que darken, que rock gets sharper, bigger and voluminous.



Lvl 2 props

- **Pipelines:** These pipelines are air pipes that help the heating of the lab, transporting it to a heat pump in another part of the building. These are across the hallways and outside the buildings. Their form is cylindrical and can make 90 degree curves. Their color is orange with some green details, that will act like the pipes have wear. These have no animations and lights. Every 5 seconds a smoke particle is activated, making a sound representing the air escaping.

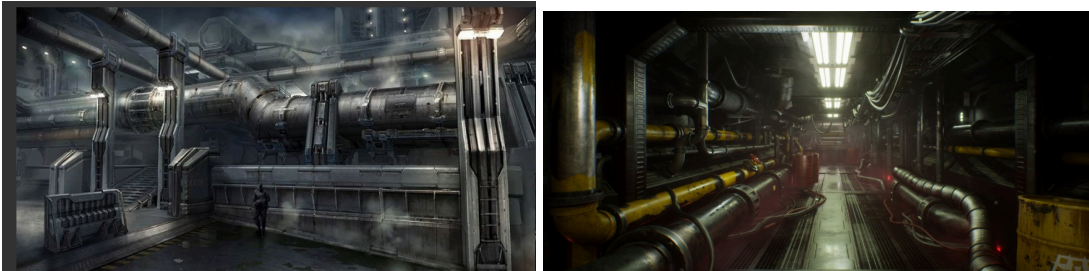

- **Columns:** These columns support all the building of the lab. These are located at the servers room, supporting the metal hallways and in the corrupted chambers. Their form is octagonal, being bigger at the top and the bottom. Their colors are gray with orange details at the top and bottom of the column. These columns have a little blue light that is emitted at the bottom and at the top.



- **Monitoring consoles:** These consoles are the ones used to control all the things in the lab: biotic tanks, servers, reactors, etc. These are located across the lab, exactly at the servers room, the reactor room and the entry of the lab. These consoles are formed by two elements, the table that contains the keyboards and controllers, and the monitors. The table is gray, with yellow details and the monitors are black, except the screens that are blue with data details. The screen emits a low intensity blue light. A monitoring sound can be heard if the player is close enough.



- **Biotic liquid tanks:** These tanks once contained aliens, now only biotic liquid is inside. These are located in the corrupted chambers. These are cylindrical and have a metallic recoverment at the top and bottom. The recoverment is gray, meanwhile the tank is green, emitting a light of the same color. If the player is near one of them, it could be heard as a bubble popping sound.



- **Reactor:** These reactors bring power to the lab. Is located in a specific room called, reactor room. Is spherical and is supported by a circular base, with some bars. The reactor is gray with some blue lines that emit light. The base is black gray with orange details. On the base there are some orange lights. A sound of a futuristic machine sound when the player is in the reactor room

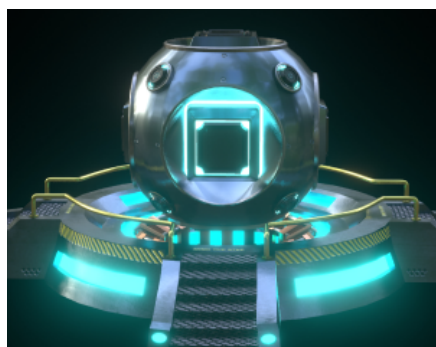

- **Vents:** These vents help with the air circulation in the lab, but the system is broken. These are located on the lab walls, minim one for room and hallway. Their form is square shaped, and are formed by laminates. These are metallic and gray. From inside the vents a white smoke comes out, covering the ground a little.

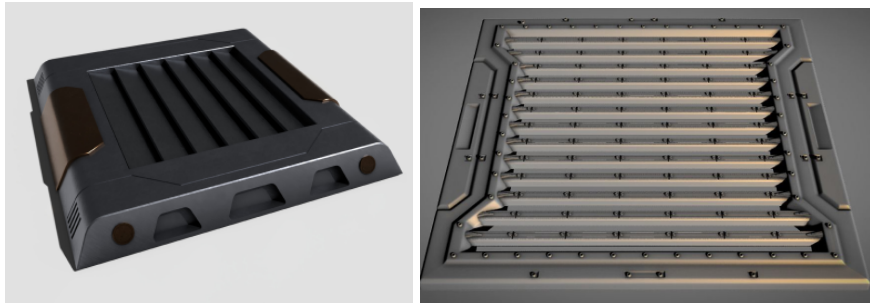

- **Large cables:** Used to give power to the lab elements like the reactor or the monitoring consoles. These are located in the rooms where the elements mentioned earlier are located. They are black and come out of a metallic gray box. Every 10 seconds sparks come out from the metal boxes. When the spark appears, if the player is close enough, the sound of the sparks can be heard.



- **Industrial luminaire / Energy columns:** Used to give light to the lab. These are located along the level. These are slim cylinders supported by four legs. These legs are yellow, meanwhile the light that comes from the cylinder is white with blue touch.



- **Servers:** Used to save all the data from the experiments made on the lab. These are located in the server room, near to the elevator. Their form is rectangular and taller than the player. They are blue with light gray details and from the front of the servers a low intensity blue light comes out. A monitoring sound can be heard if the player is close enough. A blue particle dot appears blinking every 5 seconds at the front part.



- **Metal boxes:** Used to store material from the experiments. These are located along the lab. They are cubes, with the borders a little bit bigger than the rest of the box. They are gray with blue details at the borders.



- **Electric traps:** These traps are located in specific locations marked in the [map](#). The form is a tesla coil, that does an electric circular zone around it that makes damage to the player. This electricity will be purple. The electricity particle will appear every 3 seconds, and will stay another 3 seconds. An electricity sound can be heard when the player sees the trap and it is active. Deals 220 damage.

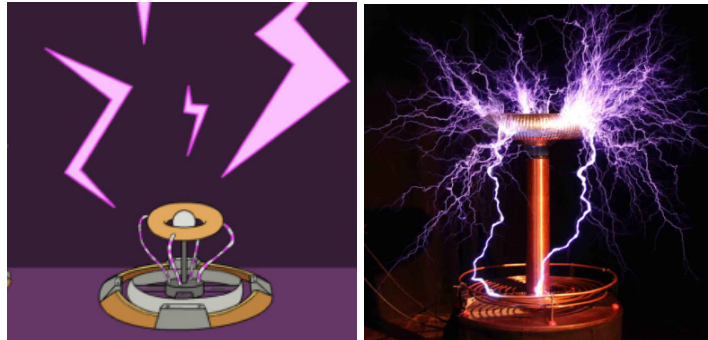
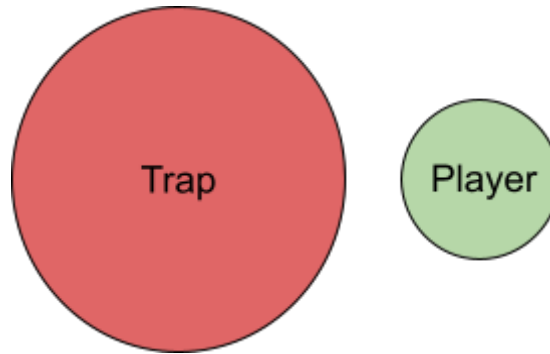

- Loot Chest:** These have interesting materials for the player. Located in specific zones marked on the [map](#). These have a rectangular form and are divided in two parts, the box and the cover. Once the player opens the chest, the cover goes up 120°. They are white with yellow details, and a little screen that acts like a lock. They have a yellow light that marks them interactable. Once the chest is opened it makes a sound, and a light ray comes out of the chest once fully opened.



- Access Key:** Used to access some rooms, these in particular the servers room. Located in one of the hallways of the lab. Is rectangular with sharpened edges. The color is red, to make it distinguishable from other elements. Also a red light surrounds the card, to praise the importance of this key and attract the player.

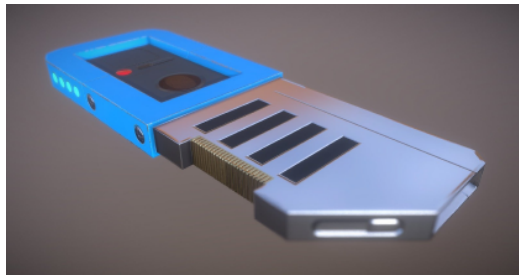

- **Lab chair:** Chairs used by the lab personal. These are located in front of the controlling monitors. These chairs have wheels, armrests and cushions. The chair is basically light gray and the cushions dark gray. They are static and impossible to move.



- **Holographic Screens:** Used to show dates while the employees were working. Located in the first room of the lab and the reactor room. These are mostly texture oriented, when it comes to modeling it can be as easy as a plane. The color of the screens is blue, and they are supported on the edges by metallic pieces. They emit a low intensity blue light.



- **Elevator:** Used to move across the lab levels. Is located at the servers room. Is circular. Is not planned to see inside the elevator while it is moving, but the platform where the player stands inside the elevator is necessary. Technically are two assets, the outside of the elevator (the circular column) and the inside platform. The elevator has a door that opens, from the middle to the sides in two parts. When the door is opened it makes a sound of futuristic door opening, and

when the player uses the elevator a sound that represents the movement of the elevator can be heard.

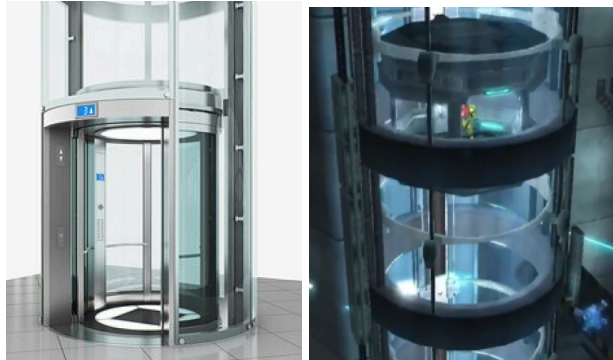

- **Dead body:** Generic dead body person, with scratches and burns (this asset will be used in other areas)



- **Tablet:** Ipad Air White. The color of the screen is green and emits a low intensity light with the same color of the screen.

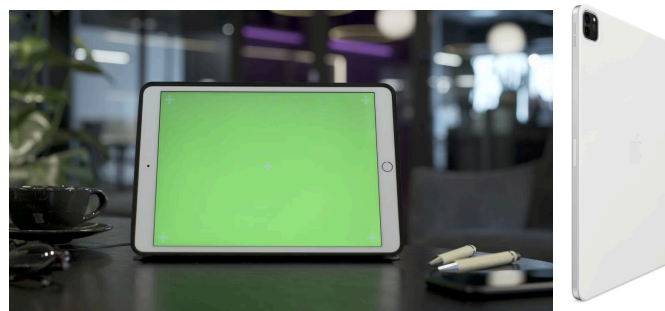

- **Alien Trap:** This trap is a giant Alien head pasted on a wall, with the tongue out. If the player touches it the mouth will close, biting the player and causing him 600

damage. When it bites, it makes a sound, also when the player touches the tongue it makes a sound too. It activates when the player is close to it (half hallway).



Lvl 2 infrastructure

- **General Description:** The general aesthetic of this level infrastructurally has to be dark sci-fi, that is, environments that appear to be moderately abandoned and taken over by the enemies of our game, slightly worn, nothing new and/or too bright to maintain that dark and gloomy aesthetic. [Except for the intersection room, which is very well lit with cold colors instead of warm ones, to give even more light].

- **Floors:** There will be 4 types of floors (excluding *Hallways*):

- *Basic Lab Floor:* this type of flooring will consist of a metallic texture with horizontal engravings in the form of lines inside of a square shaped-tile. This floor will be present only in rooms marked with a *blue 1*.

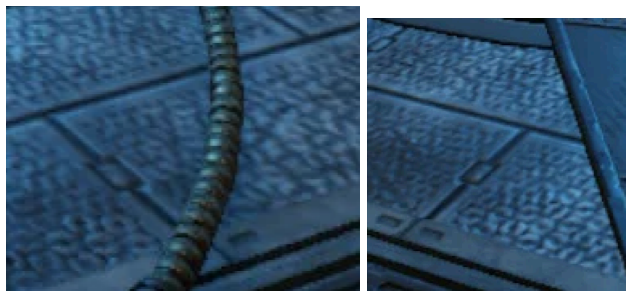

- *Lab Gateway Floor:* this one will be present only and especially on the walkways (the areas marked with a *blue 2*). They consist of a metallic texture with a non-slip industrial style engraving.

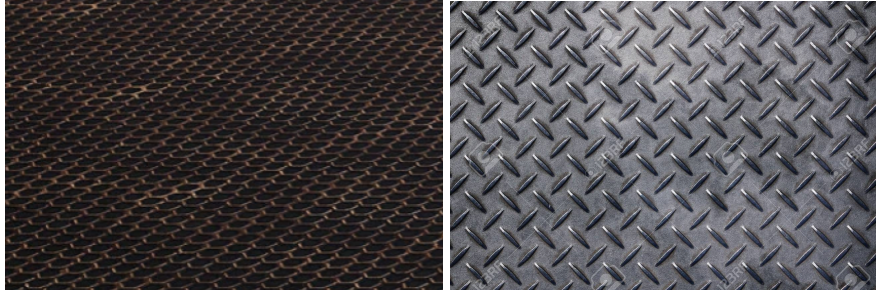

- *Corrupted Lab Floor*: this one is categorized as the most special: it has a design similar to Basic Lab Floor, with some blood stains, veins, organic material... (H.R Giger). This flooring will only be visible in part 2 of the level (marked with a *blue 3*).



- *Server Room Floor*: As for this last type of floor, it focuses only on a grid floor, that is, they are very thin sheets grouped together. It can, as usual, be complemented with details by adding cables, rivets, screws... but keep the original design simple and clean. This one is marked with a *blue 4*.

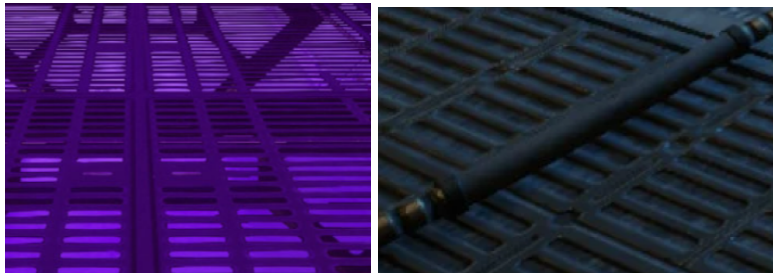

- Hallways:

The corridors/hallways will have their own structure, as they should be *made together* and *modularly* as similar to a corridor of the reference: (make *two versions* of each, one version with the following elements and another version without) with cables hanging from the walls and even present in the floors (add these assets in specific, some bigger than others, play with the size), holes to make room for ventilation systems (as they will be used as spawners of enemies), the floor will be similar to the Basic Lab Floor but without the engraving (only the square-shaped tile) and to finish the general structure and shape of these corridors -imagine that we are seeing them in first person- will be pentagonal-shaped. These corridors are marked with a *purple 0*.



- **Walls:** There will be only 3 types of walls (excluding *Hallways*):

- *Basic Lab Wall Interior.* As for the structure of these walls, it is a geometry similar to that of the hallways but without being as closed or having that aesthetic as a conduit that connects other rooms, that is, using slits in the wall and being a little less angled (not pentagonal as mentioned before in the hallways). Try to detail these walls using pipelines and emissives.



- *Basic Lab Wall Exterior.* These type of walls are mainly flat but with the corners of the ends flattened (to reinforce that sci-fi feeling). Likewise, they will keep those square tiles (can be the same ones used in *Basic Lab Floor*).



- *Corrupted Walls:* The design of these walls is quite detailed (the pentagonal geometry returns similar to that of the hallway walls) with many tubes/veins superimposed on each other making curved shapes (the fewer straight details the better). Maintain this H.R Giger aesthetic.

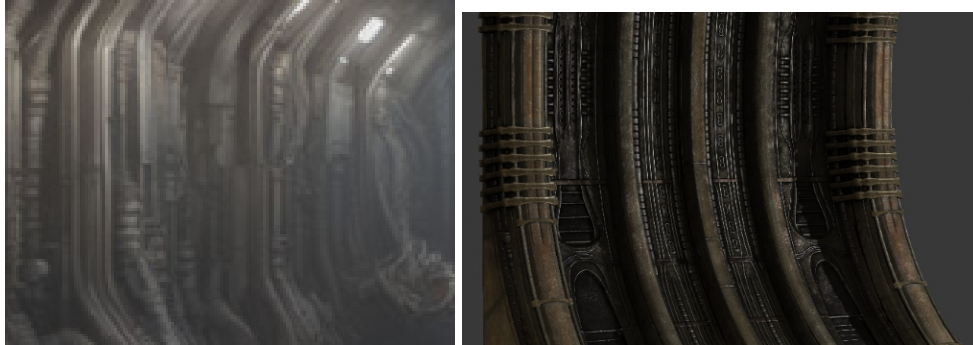

- *Server Room Walls:* These walls have a unique geometry: the wall (of a dark grayish tone) as such is angled towards the inside of the room, supported by not very thick white columns that rest on the walls following their original orientation.



- **Doors:** There are going to be 5 different types of simple sci-fi doors

- *Large Entrance Door (1st Part):* This huge door will have several layers since it is a hermetically sealed security door. It consists of the typical red light bulb that rotates like a siren to warn of its closure. This specific one will consist of three different models in one: the first is divided into two (that is, it closes horizontally), the second is the same but closes diagonally and the third is a large gate that closes vertically from top to bottom. In terms of aesthetics, it is metallic, it is worn and has two parallel slots on the sides of the divisions (with the exception of the gate, it has a large central slot).



- *Large Exit Door (2nd Part)*: This door is a large metal gate with spiral engravings and H.R Giger details (like those mentioned in previous models: a lot of organic matter and veins but maintaining that metallic and mechanical appearance below.

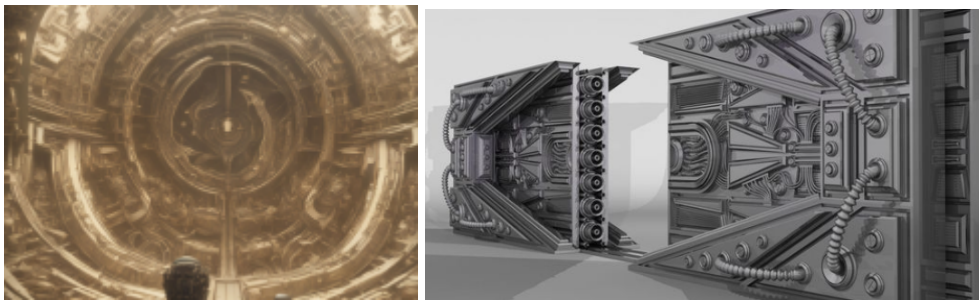

- *Basic Lab Door*: The design of this pentagonal door consists of five (triangular) closures. As for the position of the door on the wall, the lower edge will be connected to the floor and aesthetically it will have to be metallic with some emissive. Everytime the door opens a particle of pressured air appears where the door opens.

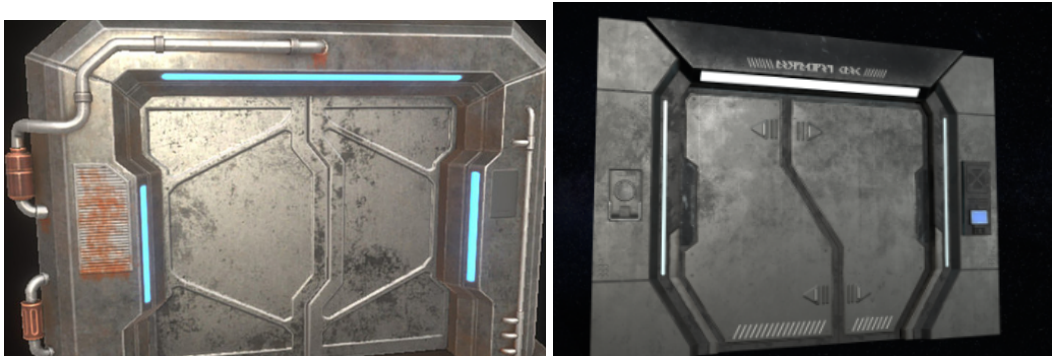

- *Intersection Door*: This type of door will be quite different from the one discussed above. It is a rectangular door (similar in shape to the Large Entrance Door) slightly larger in size than the previous one, with claw scratches and engravings similar to those of the first door described. Everytime the door opens a particle of pressured air appears where the door opens.

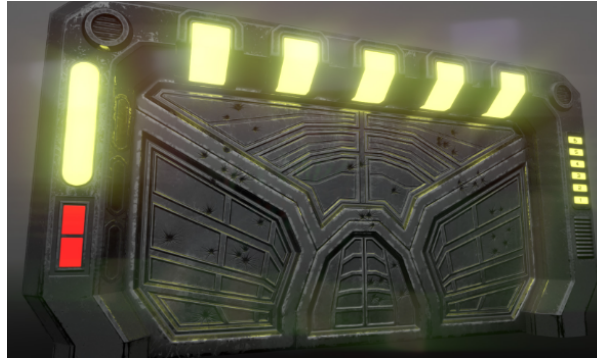

- **Ambient Exterior:** There is only one non-navigable and purely visual environment at this level: it is a background in which you can see, in the area of the walkways, a dark floor at a great depth and how the columns go from the base of the walkway to the the back of the stage.

Lvl 3 props

- **Nest Arteries:** These large, columnar veins maintain the structure of the walls and always connect to the ground. As for their shape, they are mainly cylindrical but with an extra cylinder embedded in the middle. As for their aesthetics they are mainly as shown in the visual reference, you can play with greenish and/or red tones.



- **Floor veins:** These vein-like tubes serve mainly to transport blood, nutrients and energy to the hatchery. They are thick enough to be tripped over (as big as a human leg), they can become bifurcated but there is always a main one and it is bigger. Aesthetically they are similar to the columns mentioned above.



- **Egg Holders:** These are simply a type of column with a hole or with a bag to hold/incubate eggs or to be a resting place for Facehuggers and Drone Xenomorphs. It follows the color palette of the previous assets.



- **Alien Egg:** It is rounded, large and with three cuts in the upper part of it for the drone or brood ('zángano') to come out. These eggs can be open or closed, if they are closed they maintain saturated tones and have a moist texture, while if they are open they are dry and desaturated.

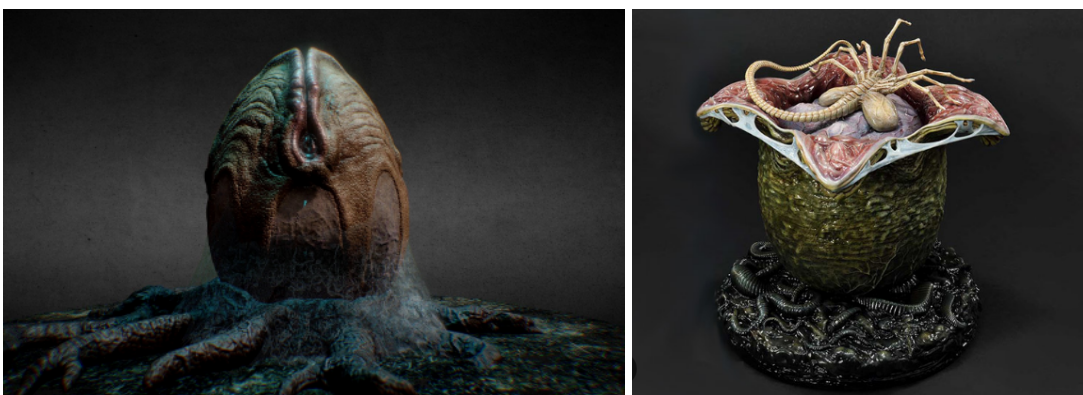

- **Nest Chest:** This chest is identical to those found in other levels except that it is covered with biomass and veins, the result of being corrupted by the area in which it is located.



Lvl 3 infrastructure

- **Basic Wall:** These walls are rough and with a texture similar to that of a palate (what a mouth would look like on the inside).



- **Venous Wall:** This type of wall starts from the base of the basic ones but has a large accumulation of thin veins intertwined with each other. The wall itself is of the same color palette as the previous elements, but the veins are much more reddish and intense.



- **Queen Chamber Wall:** The cracked and dry walls of the arena are of a whitish color with red tones, full of spots, but without veins. They are reinforced by small columns that adhere internally.



- **Basic Floor:** This floor, being the most basic, is the simplest: it is still the rough texture of the wall but more noticeable and adding some veins as if they were passing inside.



- **Bio-Compound Floor:** This type of flooring is a composite of veins, flesh and bone that simulates a much more solid surface than the previous flooring, using the same color palette.



Queen Chamber Floor: the floors of the arena, unlike the walls, are brownish and dark, as if they were made of bones and corpses.

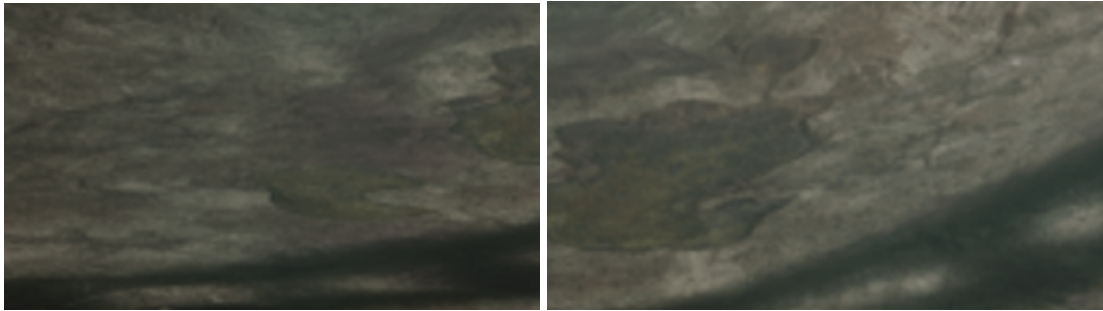

- **Flesh Door:** This structure resembles that of a conventional door, only that it is made of organic material. When closed, it has a gland in the center that emits a warm light.



6.9 Assets Particles

General

- **Chest Loot:**

The particles inside the chests will be designed to create a feeling of excitement and wonder when the chests are opened. As the player opens a chest, an explosion of glowing particles will emanate from within, radiating outward a yellowish-white light. These particles will glow, catching light in various colors, adding to the magical feeling of discovering treasure. The movement of the particles will be fluid and dynamic, creating a feeling of energy and anticipation as the chest opens.



- **Steam pressure (structure tubes in levels):**

Particles inside the tubes scattered throughout the levels will cause a release of gas or vapor from the alien base's infrastructure. As the player navigates the levels, they will encounter these tubes that emit wisps of swirling particles, giving the impression of a leak or clandestine vent. The particles will be tinted gray.

The movement of the particles will be erratic and turbulent, as if invisible forces inside the tubes are pushing and pulling them. Occasionally, small bursts of particles may emerge from the tubes, adding to the feeling of unpredictability and instability.

- **Wire spark effect:**

Sparks emanating from electrical wires will add a dynamic and dangerous element to the environment, increasing the sense of danger. As the player progresses through the levels, they will encounter wires cracking with electrical energy and sparks flying between the wires.

The sparks will be bright and intense, with a vivid glow that will illuminate the surrounding area. They will vary in size and intensity, sometimes flickering with smaller sparks and other times exploding into larger bursts of energy. The colors of

the sparks will vary from fiery white to shades of blue and violet, conveying the immense power that flows through the wires.

The movement of the sparks will be erratic and unpredictable, that is, the direction in which the spark jumps from the cable will be randomized.

Reference:

https://www.youtube.com/watch?v=fj1TvWr88mk&ab_channel=JeanNieves

Base

- **Workstation (Upgrade Weapons & Crafting):**

The particles will resemble molten metal, glow with intense heat, and radiate a vibrant orange hue.

The movement of the particles will mimic the fluidity of liquid metal, flowing and merging before solidifying into the final product. Sparks may occasionally fly from the workstation, adding to the dynamic nature of the crafting process.

As upgrades are applied, the intensity of the particle effect may increase, conveying the increase and improvement of the player's equipment. The sound of crackling energy and the hum of machinery will accompany the visual spectacle, immersing players in the sensation of creating powerful new equipment.

Reference:

https://www.youtube.com/watch?v=10F-Oz0_j68&ab_channel=CineHD (Min 1:53)

- **Teleporter & Beacon:**

The teleportation and beacon effects in our game will feature a particle system, which, as players activate the teleporter, glowing blue particles will cascade from the ceiling, creating an ethereal, otherworldly atmosphere.

These particles will have a soft glow and descend gently, increasing the feeling of anticipation and wonder. Along with the particles, concentric rings of blue energy will materialize, floating above the teleporter platform.

The rings will pulse and undulate, emitting a slight hum, as they indicate the activation of the teleportation mechanism. Together with the falling particles, they will create a fascinating visual spectacle that will draw players towards the teleporter.

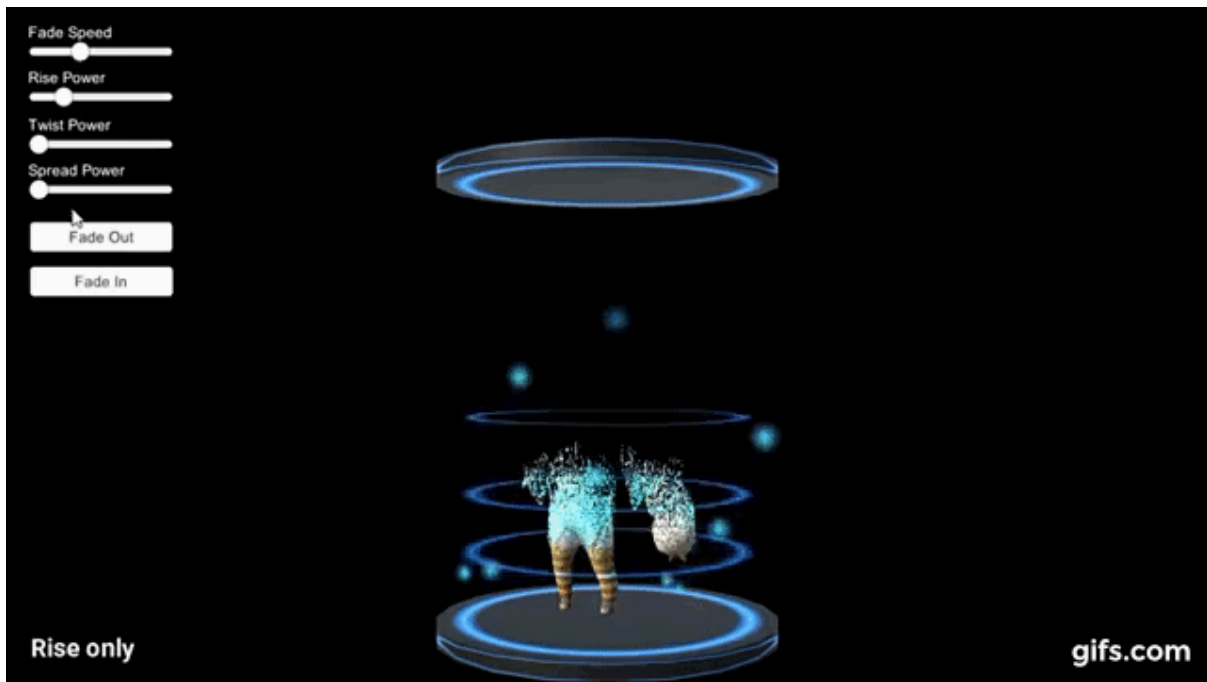

Level 1

- **Broken wires:**

Particle effects from broken wires spread across the map will represent the danger of exposed electricity with sparks and short circuit visuals.

The sparks will vary in intensity, with some smaller ones flickering sporadically while larger bursts will fire unpredictably.

The colors of the sparks will vary from bright white to shades of blue and purple, indicating energy flowing through the exposed wiring.

Reference:

https://www.youtube.com/watch?v=n3eddpYVaDw&ab_channel=MrDalekJD

(Min 1:03 in the generator on left)

Level 2

- **Gas Trap:**

The particulate effects of a toxic gas trap emitting a purple haze will emphasize the danger and toxicity of the environment.

A dense cloud of purplish gas will rise outward, enveloping the surrounding area in a noxious fog. The particles within the gas will be a sickly hue, ranging from deep purple to lavender, and will pulse with an ominous glow.

Reference:

https://www.youtube.com/watch?v=jQivfs34Wb0&ab_channel=AqsaNadeem

- **Tesla Trap:**

Same as with the particles of broken cables, but with larger arcs as in the following reference:

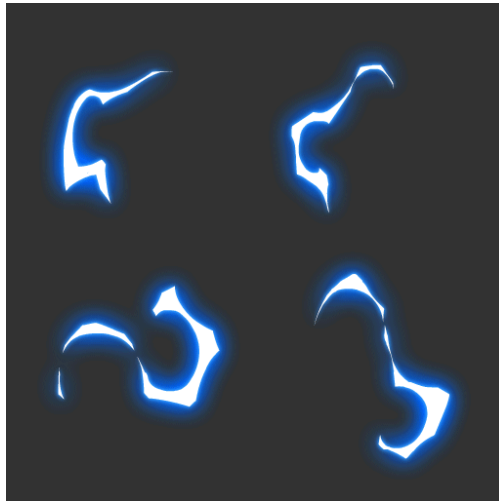

7. User Interface (UI)

7.1 HUD (Head-Up Display)

- The HUD should reflect the tension and horror of the genre and IP.
- Dark visual style with neon and holographic elements, suitable for a "sci-fi horror" ambiance.
- Alerts and HUD information should be quickly interpretable in high-stress situations.

Enumeration of the elements used on this HUD and referenced in the designs below:

1. Banner information: Displays essential data such as current location, contamination alerts, oxygen levels, and quarantine warnings, intensifying the environmental tension.

2. Key card: Shows if the player has a key card. The player can only pick up one key per raid, so only maximum one key sprite will be shown at a time. When a player enters a level (or exits it) he loses the key card. The card has only one use, so once the player uses it, it disappears (the sprite in the HUD hides).

3. HP (Health Points): Features a health bar with a technological aesthetic, including flashing effects or static when taking damage, aligning with the "sci-fi" theme.

4. Dash: A single slot for special abilities and quick evasion.

5. Skills (3): Provides three slots for special abilities.

6. Weapon icon: Displays the currently equipped weapon, possibly with a graphical representation of its state, such as overheating or contamination by alien bio-material.

7. Ammunition: It should be clearly visible and perhaps show different types of ammunition for different weapons.

8a. Consumable ready to use: Indicates items like grenades or temporary boosters that are primed for use, with icons that activate or illuminate upon activation.

8b. Consumable not selected: Distinguished by transparency or another visual cue to inform players of unselected items.

9. Change consumable icon: Allows players to easily switch between consumables, enhancing tactical flexibility.

10. Boss health bar: An important element for boss fights, it could have a design that integrates with the overall "sci-fi horror" aesthetic.

12. Map button: Enables quick access to the map.

13. Inventory button

14. Curas (Health potions): Displays available health potions with a maximum limit.

HUD2-Xavi

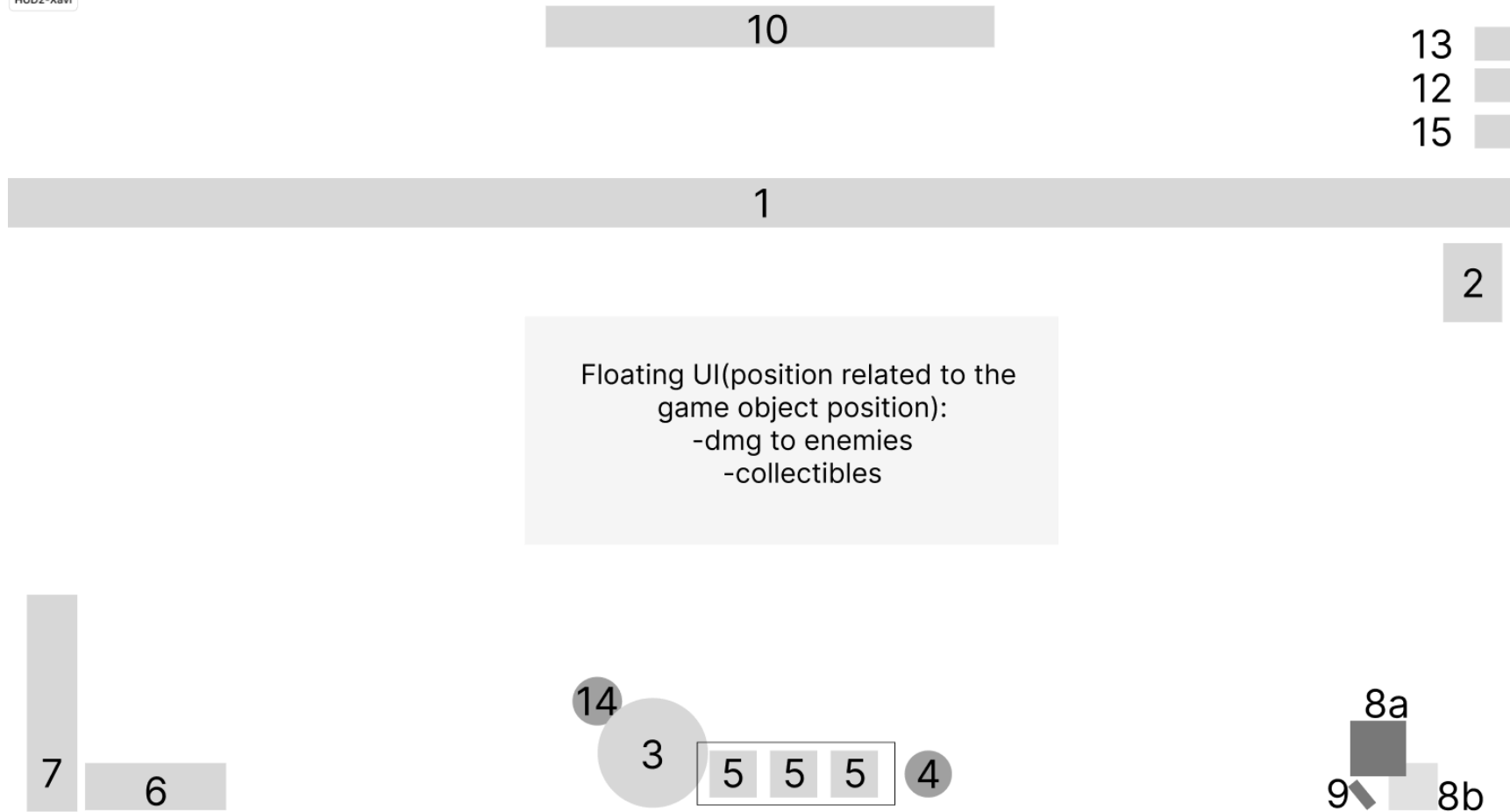

7.2 Inventory

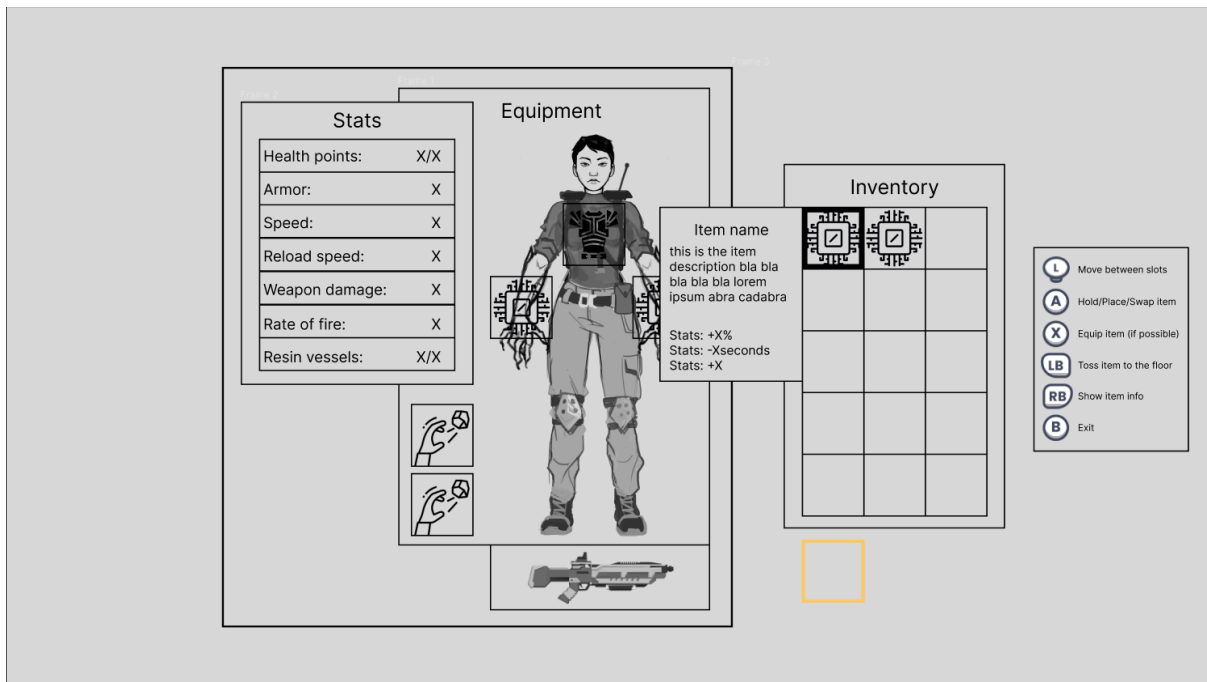

The inventory consists of two parts:

- The equipment, where the player can see his stats and manipulate the items equipped: The armor, two chips and two consumables.
- The item slots, where the player has all the items he picked up while raiding. There's one separated slot, that is the safe slot, if an item is placed there and the player dies, that item it's not lost.

The player can navigate through the item slots and the equipment slots by just moving the hover square with the left stick.

The weapon square is not hoverable

When an item is hovered, the player can hold the RB to show the name, description as well as its stats

When an item that slot is selected, is marked with the same square as the hover one but with a grey color instead of black.

“X button” to equip the hovered item automatically. If there's an item equipped in the same place the player is trying to equip it, the position of the two items swap, so the equipped item goes to the item slot and the item in the slot goes to the equipment slot (for example, if an armor is equipped and the player hovers over an armor in the inventory and uses the X button, the equipped armor and the one hovered swap places). If the player uses the

autoequip on a chip, and both chip slots are used, it swaps the hovered chip with the left chip slot.

Inventory navigation map

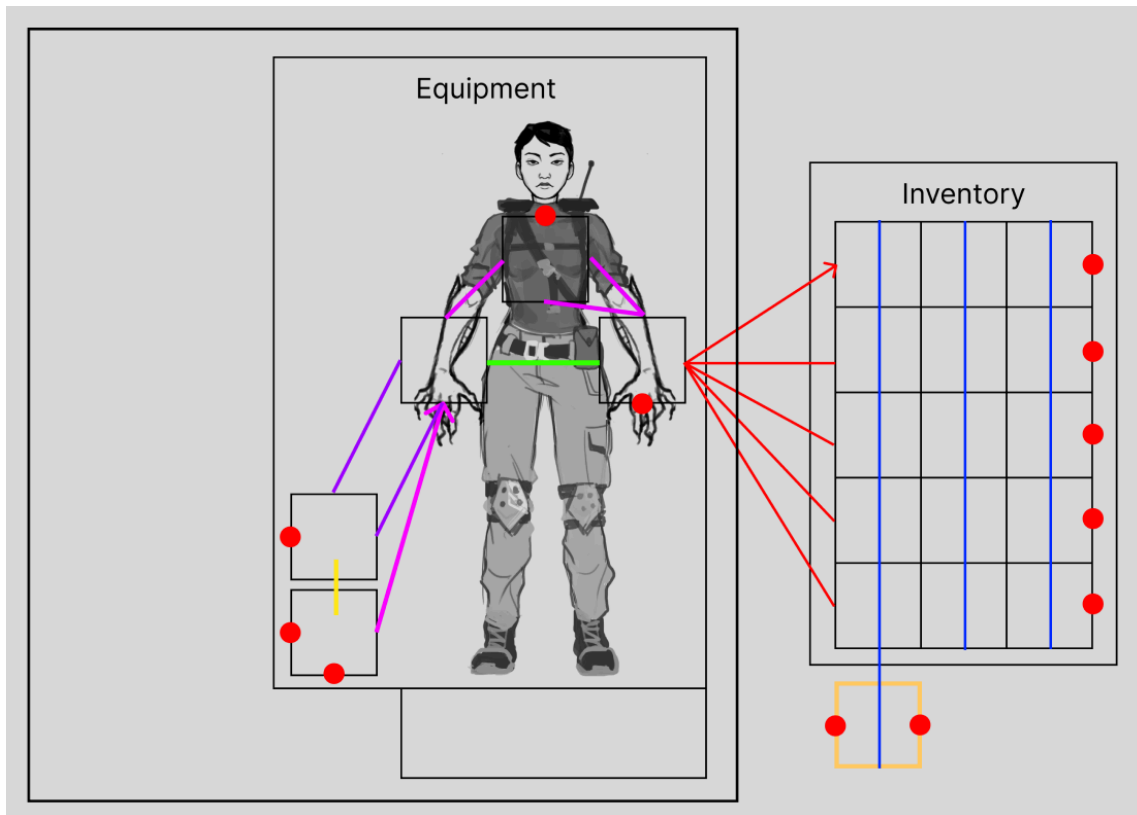

Items descriptions

Exo-Armor:

- Description: An exo-armor that will help you withstand the blows of Xenomorphs. It's light and tough, much better than marine tech.
- Stats:
 - Common → Dmg Reduction: +10%
 - Rare → Dmg Reduction: +18%
 - Epic → Dmg Reduction: +25%

Offensive chip:

- Description: A thin layer made of aluminum bone with thin and sharp canals. Boosts the offensive capabilities.
- Stats:
 - Common → Speed: +1, Reload Spd.: +5%, Dmg Multiplier: +12,5%
 - Rare → Speed: +2, Reload Spd.: +9%, Dmg Multiplier: +24%
 - Epic → Speed: +3, Reload Spd.: +15%, Dmg Multiplier: +45%

Defensive chip:

- Description: A thick layer made of aluminum bone with many thin canals spread around various layers. Boosts the defensive capabilities.
- Stats:
 - Common → Dmg Reduction: +5%
 - Rare → Dmg Reduction: +9%
 - Epic → Dmg Reduction: +12,5%

Alien Skin:

- Description: This is made of a tough material, capable of resisting the creatures' own acid.

Alien Claw:

- Description: Shiny, black and extremely sharp claw, capable of slicing through almost anything within its grasp.

Alien Tail tip:

- Description: A sharp metallic piece of the tail, they use it as a slicing weapon.

Alien Acid Vesicle:

- Description: Acid-filled organic bags, can be useful for some crafts.

Alien Exocranium:

- Description: An elongated shell. Hard, resistant and light. Sometimes containing some vesicles on the sides.

Alien Aluminum bone:

- Description: It is light, soft, malleable, and a good conductor of both electricity and heat.

Alien Core:

- Description: An amazing but unknown part of the alien, it can be used to upgrade your weapon.

The **rarity** of the item will be shown by a **colored square** behind the item:

- **Common:** Green square.
- **Rare:** Blue square.
- **Epic:** Purple square.
- **Mythic:** Red square.

The player can throw an item on the floor with “LB” ONLY in raid.

7.3 Crafting

The image shows a crafting station interface. On the left, the "Crafting Station" has six rows of material slots. Each row consists of a square slot, a plus sign, another square slot, a plus sign, a third square slot, and an arrow pointing to the right. The bottom row has four square slots with plus signs between them and an arrow. On the right, an "Inventory" grid is shown with a 4x3 layout. The top-left slot is highlighted with a thick black border. Below the inventory is a yellow square slot. A tooltip is displayed over the top-left inventory slot, containing the following text:

Item name
this is the item
description bla bla
bla bla lorem
ipsum abra cadabra

Stats: +X%
Stats: -Xseconds

At the bottom right, a control panel lists the following actions:

- L** Move between slots
- A** Hold/Swap/Place item
- RB** Show item info
- B** Exit

Caution! Caius will craft the item automatically once you place all the necessary materials

The crafting station allows the player to craft items using materials he found in raid. He can craft by moving the items from the inventory to the crafting slots. If the player tries to place an item on a wrong slot, an error sound will be played and nothing else will happen.

Each slot has a sprite that indicates which item has to be placed there and the result of the craft will also have a sprite that shows what item will be crafted. These slots are fixed in the same menu png, since they don't change during the course of the gameplay.

The recipes of the crafts are, in the same order as the wireframe, the following:

Armor: Alien Skin + Alien Skin + Alien Exocranium

Grenade: Alien Skin + Alien Acid Vesicle

Baker House: Alien Claw + Alien Tail tip

Offensive Chip: Alien Claw + Alien Claw + Alien Aluminium Bone

Defensive Chip: Alien Exocranium + Alien Exocranium + Alien Aluminium Bone

Resin Vessel: Alien Skin + Alien Skin + Alien Acid Vesicle + Alien Tail tip

Once all the materials are placed in the crafting slots, the item will be crafted automatically and will appear in the far right slot.

The player can move the items just like the inventory.

The player can use the "RB" button to see the information of the hovered item (only if there's an item there, it does not work with the sprites indicating which item has to be placed).

If the player tries to close the inventory while there's an item in any crafting slot (material or crafted) nothing will happen and an error sound will be played.

The resin vessel works differently than the other crafts: When selected, it disappears and the max number of Resin Vessels is upgraded by 1.

Resin Vessel description: Adds one more Resin Vessel when crafted, allowing you to get more heals on the raid.

Navigation map

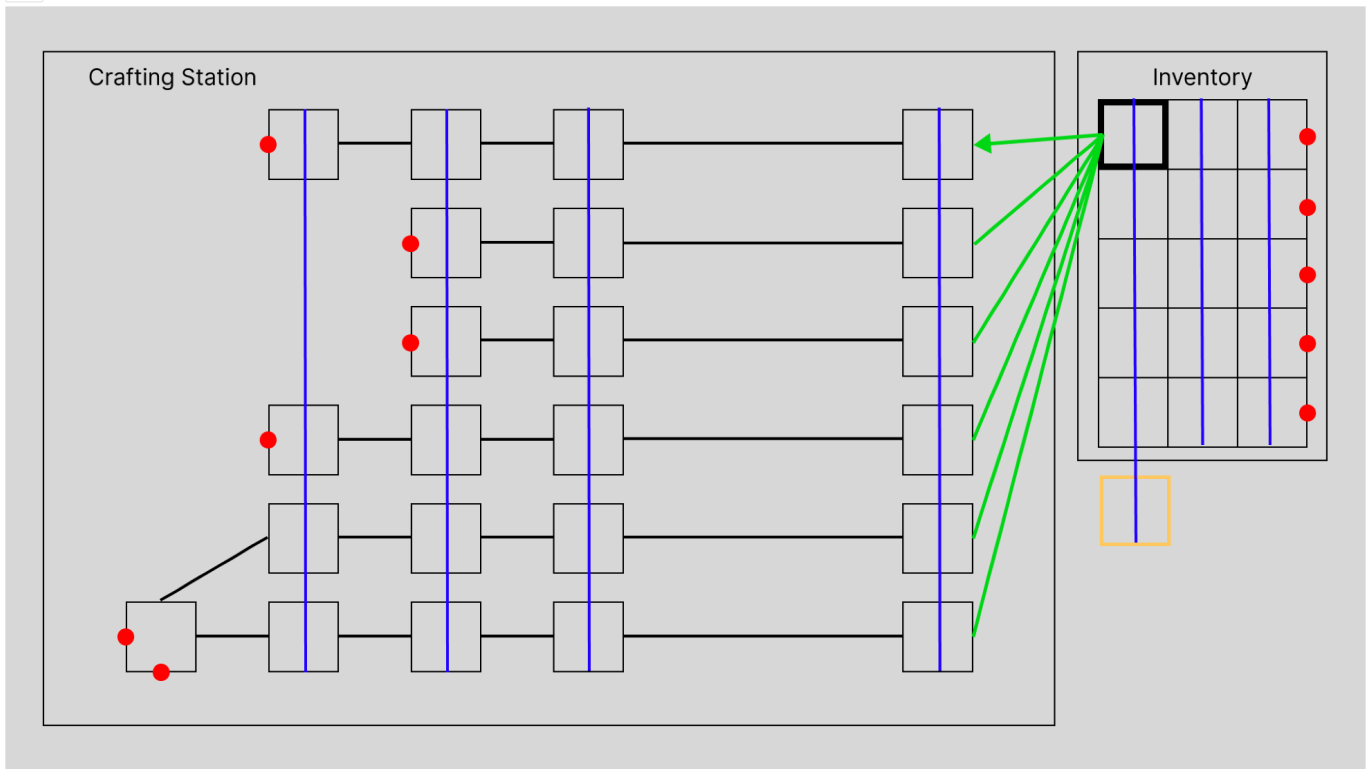

7.4 Weapon Upgrade Station

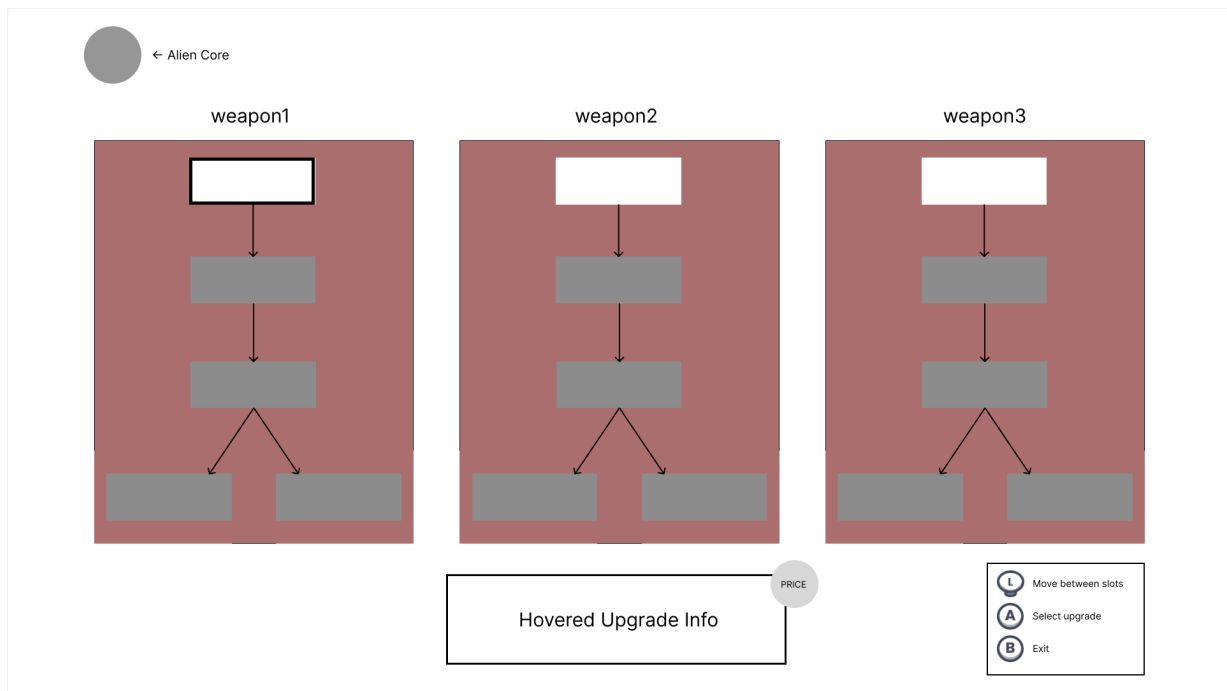

This interface focuses on presenting the upgrade paths for the three distinct weapons, each with its unique progression tree.

- **Upgrade trees:** In the central portion of the UI are the three weapon upgrade trees. Each tree represents a different weapon available to the player, structured to visually guide the player through the upgrade process. Initially, the first slot of these trees is in white, indicating that the player starts with all weapons at their base level.
 - The third level of each weapon's progression. It splits into two distinct upgrade options, allowing players to specialize their weapon according to their gameplay style or tactical preferences. In contrast, the first and second levels offer a single upgrade path, simplifying earlier choices. Once one of the two final upgrades has been upgraded, the other one gets blocked FOREVER.
- **Upgrade information display:** Below the central upgrade trees, there's a dedicated text box that dynamically displays detailed information about the hovered weapon upgrade. This includes a description of the upgrade's effects and the cost required to unlock the selected upgrade. The cost of each upgrade are: 1, 2 and 4.
- **Interactive controls panel:** Positioned at the bottom right of the screen is an informational panel outlining the controls for navigating the Weapon Upgrade Station UI.
 - **A button:** Confirms the selection of an upgrade.
 - **B button:** Exits the upgrade station screen.

- **Left joystick:** Facilitates movement across the different upgrade slots.

If the player is hovering an upgrade he can upgrade it if he has the necessary alien cores or more. An upgrade gets unlocked once the previous one is upgraded.

If an upgrade is locked, it cannot be hovered.

If an upgrade is unlocked, even if it's not upgraded yet, it can be hovered and the info is shown.

An unlocked upgrade that has not been upgraded yet, will be black, so:

- Unlocked + Upgraded = Normal Sprite.
- Unlocked + Not Upgraded = Black Sprite.
- Locked = Black Sprite with a lock.

It's important to differentiate the hover sprite to the normal and black sprite.

Upgrade Descriptions, in the same order as the wireframe:

S.T.A.P.L.E.R.

Level 0 (S.T.A.P.L.E.R.)

The S.T.A.P.L.E.R. features enhanced recoil and an extended magazine for exceptional accuracy and smooth handling in close combat.

Level 1 (S.T.A.P.L.E.R. v1.5)

Double Shot. Dual damage enhancement ensures devastating firepower, especially in close combat.

Level 2 (S.T.A.P.L.E.R. v2)

Instant Reload by dash. When the dash ability is activated, the weapon reloads automatically.

Level 3 (S.T.A.P.L.E.R. α)

Alpha Boost. Forged from alien alloys, the enhanced S.T.A.P.L.E.R. wields unmatched power and extended magazine for relentless attacks.

Level 3 (S.T.A.P.L.E.R. β)

Beta Boost. A relic of ancient power, with its ferocious rate and capacity for sacrifice, it commands fear.

SPAR-X

Level 0 (SPAR-X)

SPAR-X offers versatile bullet spread for neutralizing targets across diverse battlefield scenarios.

Level 1 (SPAR-X v1.5)

Extended Magazine: The upgrade boasts expanded magazine capacity, ensuring sustained firepower in intense engagements.

Level 2 (SPAR-X v2)

Long Barrel: Sacrificing area extension, it extends shot distance, ideal for precise engagement at longer ranges.

Level 3 (SPAR-X α)

Alpha Boost: Boosted from an unknown civilization, epitomizes nature's might with enhanced rapid fire.

Level 3 (SPAR-X β)

Beta Boost: Forged from otherworldly silver, the enhanced SPAR-X now shoots 4 bullets instead of 2, for more destructive damage.

EM-MK2

Level 0 (EM-MK2)

EM-MK2 fires a lethal energy beam for sustained suppression in medium to long-range combat.

Level 1 (EM-MK2 v1.5)

Fast Loader: Speeds magazine reload for faster ammo replenishment, cutting reload time by two thirds.

Level 2 (EM-MK2 v2)

Extended Magazine: Adds an expanded magazine for sustained firepower in prolonged engagements.

Level 3 (EM-MK2 α)

Alpha Boost: Epitomizes destructive power, with intensified fire rate and damage output unleashing relentless fury.

Level 3 (EM-MK2 β)

Beta Boost. Forged from unknown materials, this enigmatic weapon enhances combat prowess with penetrating ability.

Navigation map

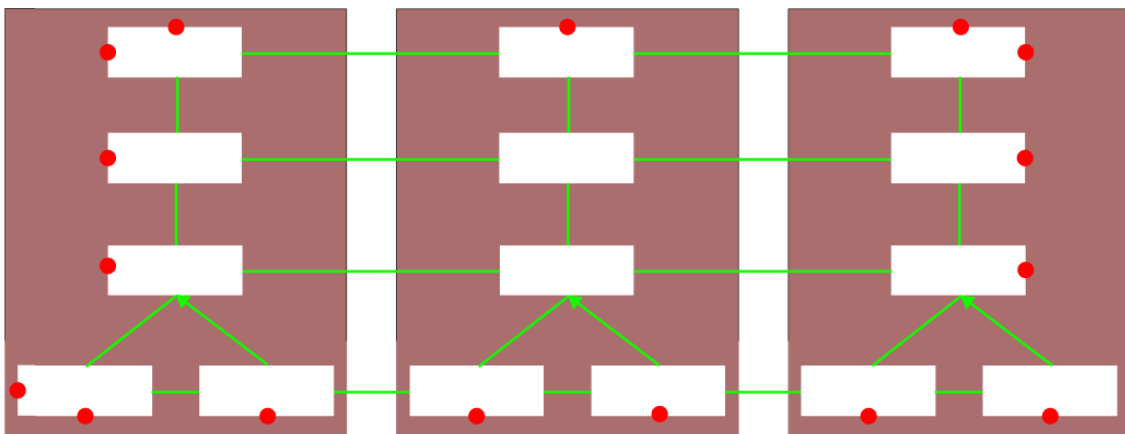

7.5 Dialogue

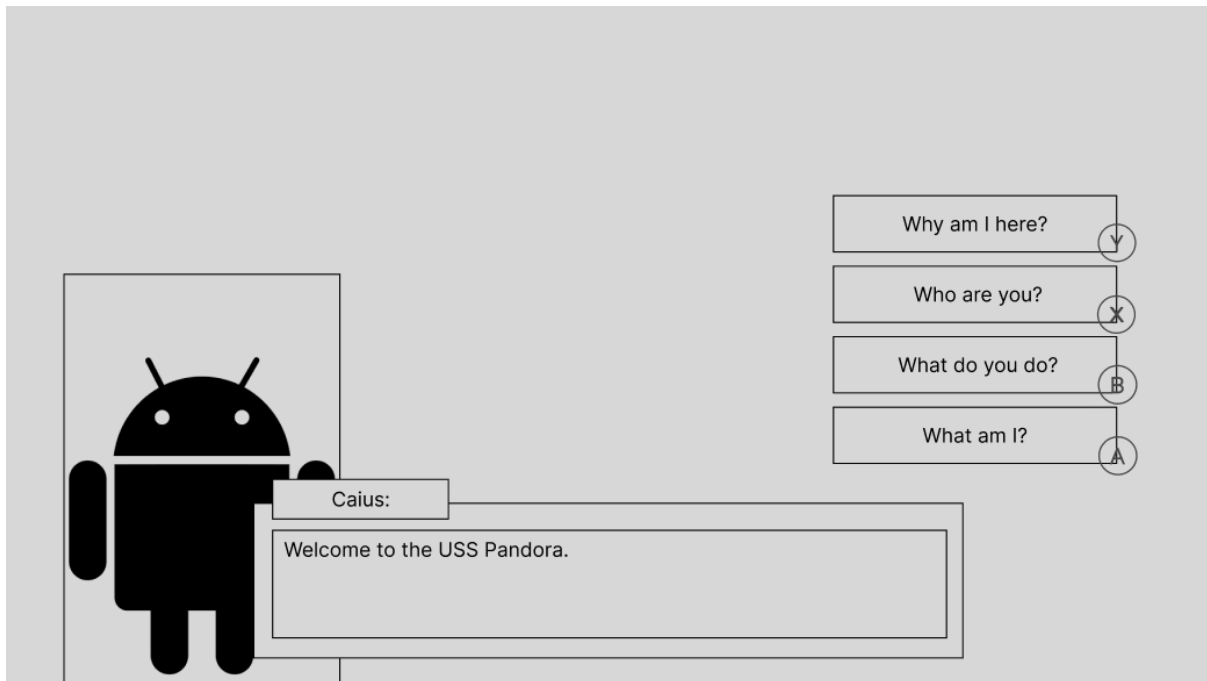

- **Dialogue box layout:** The UI displays a dialogue box that accommodates the conversation text and up to four response options. Adjustments to the box size are possible to ensure optimal readability and integration with game aesthetics.
- **Response options:** Depending on the context, the dialogue box can present up to four text options for the player to choose from. If fewer options are available, only the necessary ones are shown. In scenarios where no options are needed, a single choice with "..." signifies a continuation without explicit player choice.
- **Character image frame:** A designated area within or adjacent to the dialogue box indicates the maximum size for character images, providing a visual reference for players and enhancing narrative immersion. This frame is designed without a traditional margin, aiming for a fluid integration into the dialogue presentation, as seen in reference images.
- **Controller integration:** Crucially, each player response option in the dialogue box is associated with a specific controller button, visually represented by icons for Y, X, B, and A.
This design choice directly maps dialogue options to controller inputs, making it intuitive for players to select their desired response. The presence of these icons serves as a clear indication of how to navigate and choose dialogue options, aligning with the natural controller layout and player expectations.

7.6 Base Teleporter

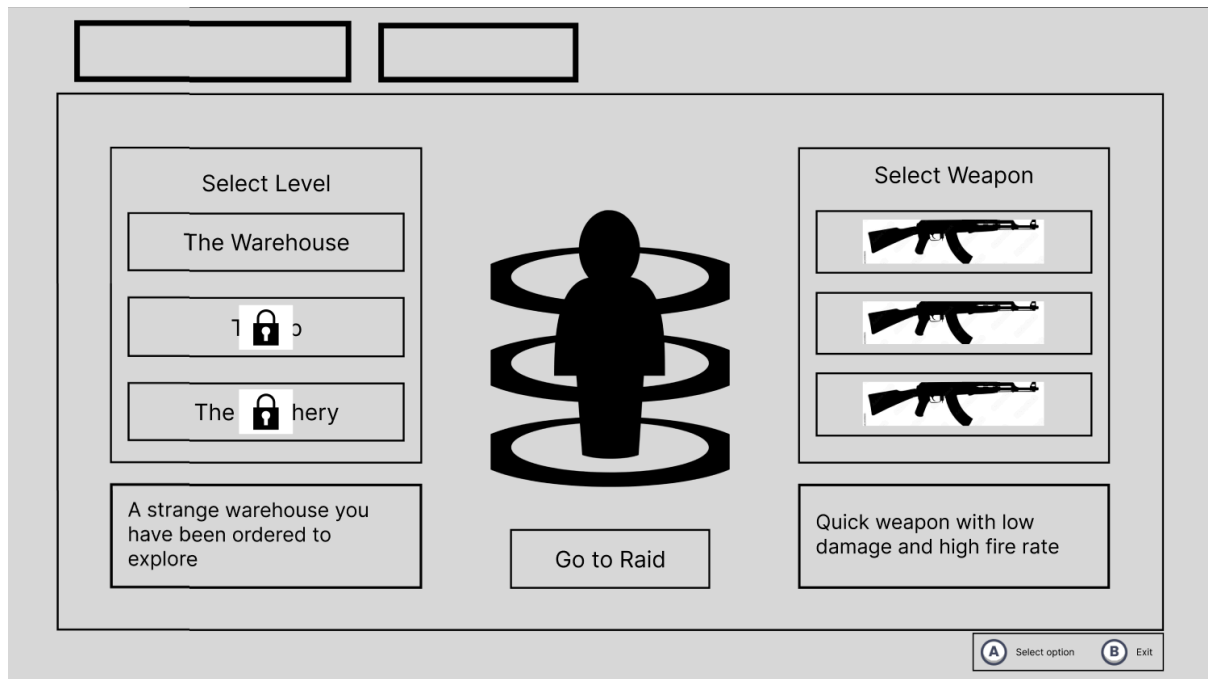

The Base Teleporter UI prominently features level and weapon selection:

- **Level selection on the left:** Levels are listed on the left side of the UI. Each level is represented visually, with unlocked levels clearly labeled and locked levels indicated by a padlock icon. This separation allows players to quickly assess which levels are available for engagement and which are yet to be unlocked. Hovering over a level reveals additional details. To unlock a level the player must have completed before.
- **Weapon selection on the right:** The right side of the interface is dedicated to weapon selection. Players can browse through available weapons, with each option visually represented. Hovering over a weapon highlights it and the menu offers a brief description of the weapon, which aids in making an informed choice based on gameplay preferences or mission requirements.
- **"Go to Raid" button:** At the bottom center of the UI, the "Go to Raid" button is prominently placed but remains inactive and visually distinct (e.g., grayed out) until both a level and a weapon are selected. Once the required selections are made, the button becomes active (e.g., changes color or illuminates), signaling readiness to proceed.

Level descriptions

LVL1: An unused warehouse under the name of Weyland-Yutani corp. It doesn't look like a dangerous place, it smells a bit burnt though.

LVL2: There are no records of this place, although it looks like a research area. A laboratory? Underground?

LVL3: If this was once a laboratory, it is definitely no longer one. All the walls, floors and furniture are covered in something black and slimy.

Weapon descriptions

Weapon 1: The "S.T.A.P.L.E.R." is a fast submachine gun capable of blasting multiple low damage bullets in less than a second, perfect for a fast cleaning.

Weapon 2: The "Spar-X" is a shotgun that allows you to eliminate multiple enemies in one shot, perfect for close-distance combat.

Weapon 3: The "EM-MK2" is a plasma weapon capable of firing a constant beam of lethal energy, ideal for suppressing enemies in medium and long-range combat.

Navigation maps:

LVL1 unlocked:

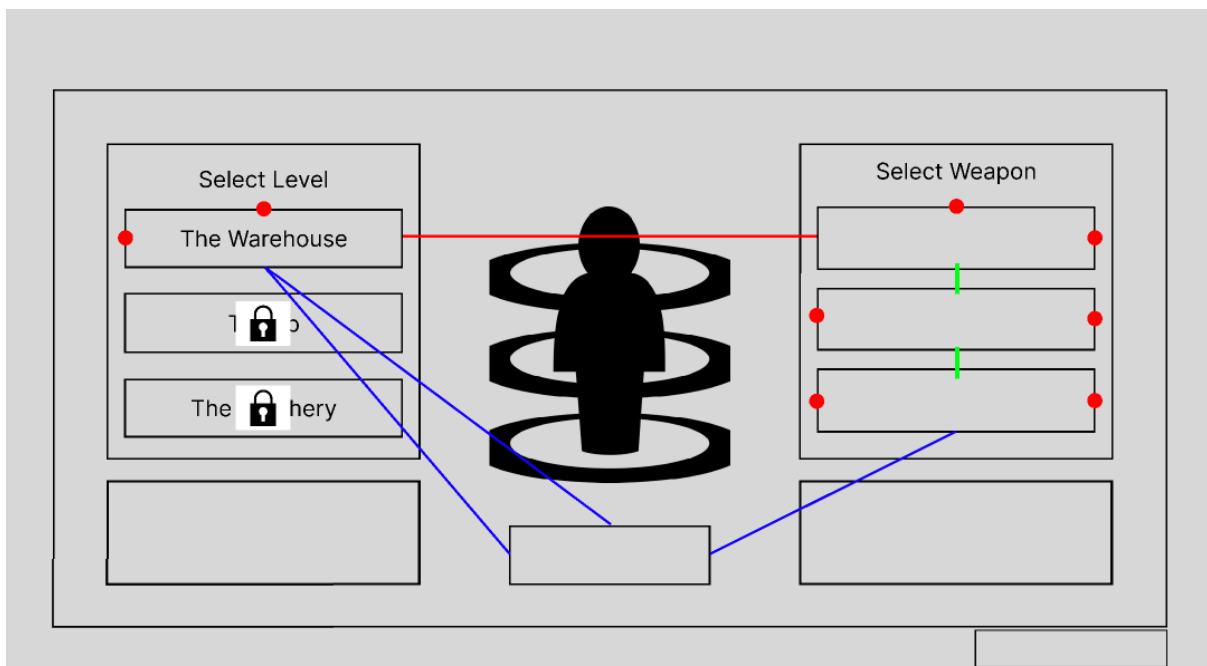

LVL2 unlocked:

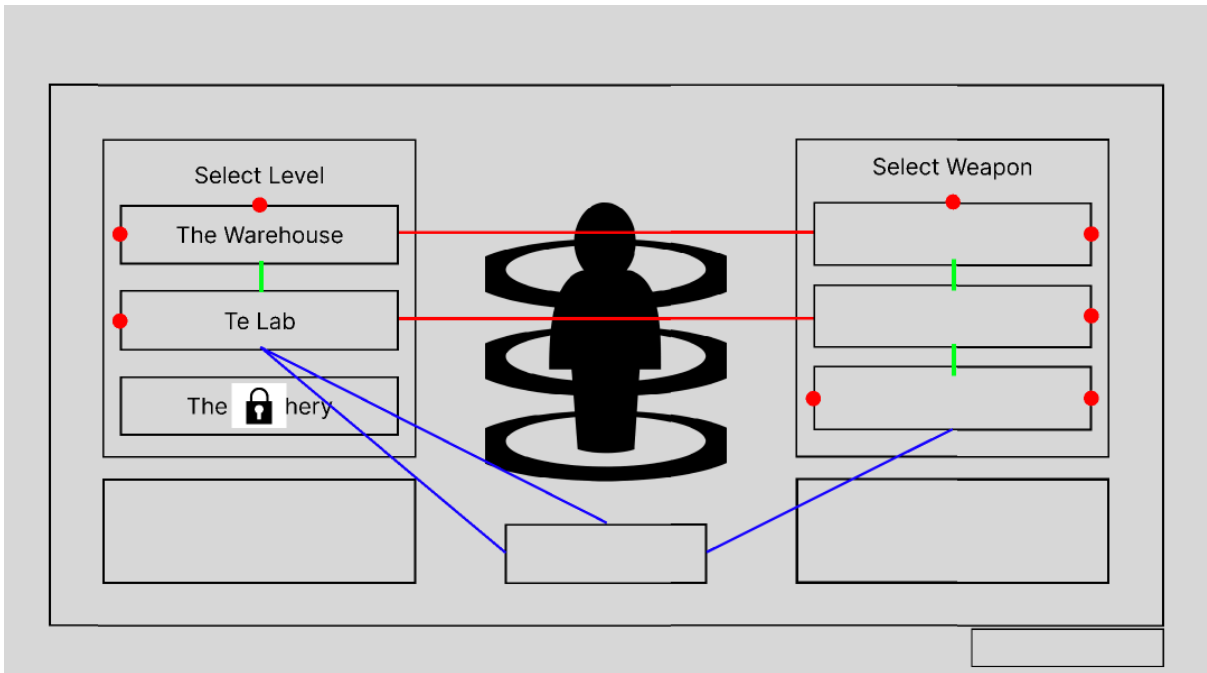

LVL3 unlocked:

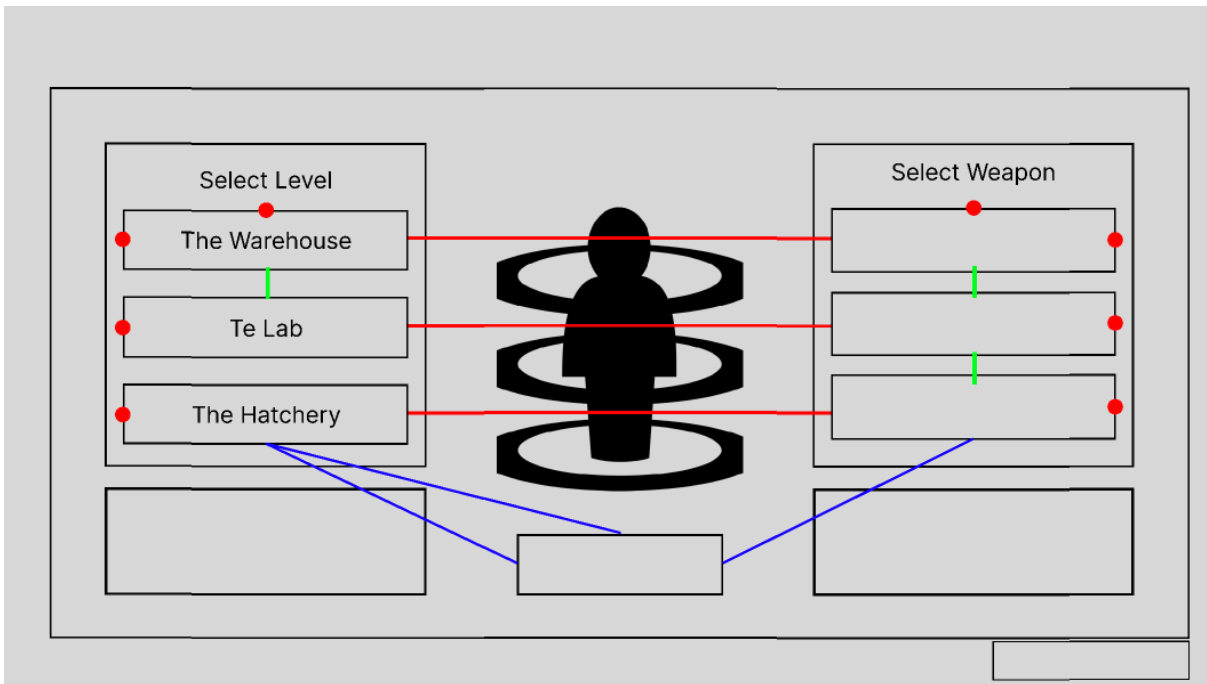

7.7 Loading screens

The loading screen will display the map of the scene in which the player will appear, with the name of the level above center and the text 'Loading...' at the bottom right.

The style would be similar to the motion tracker seen in the Alien saga.



Base

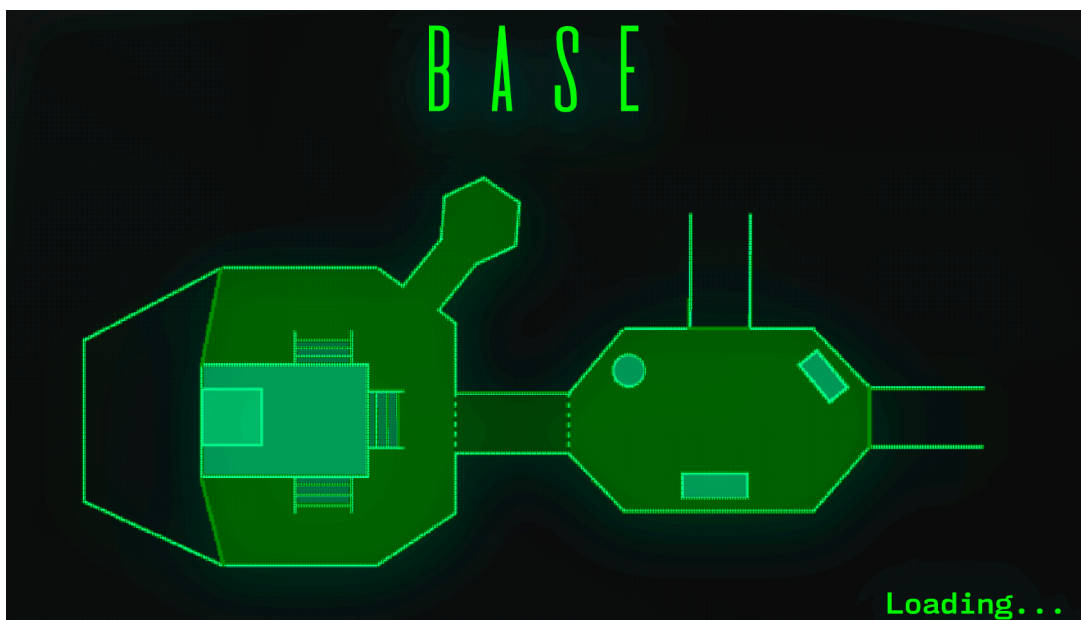

Level 1 - The warehouse



Level 2 - The lab

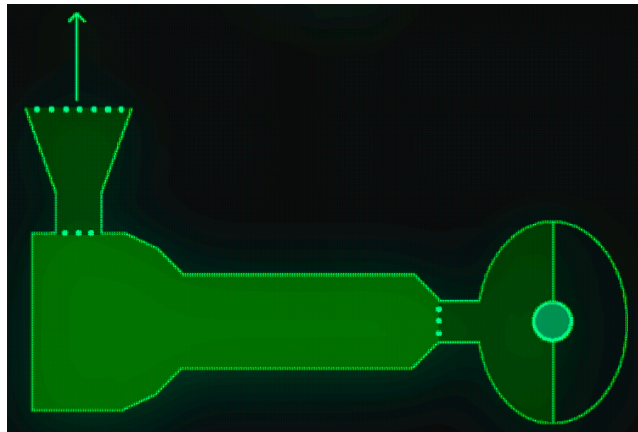

Level 3 - The hatchery

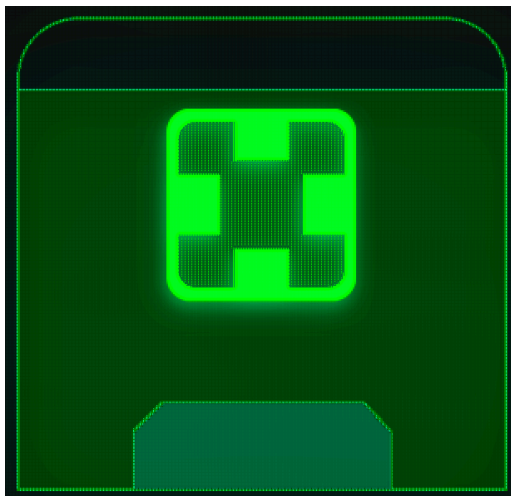

7.8 Base Stash

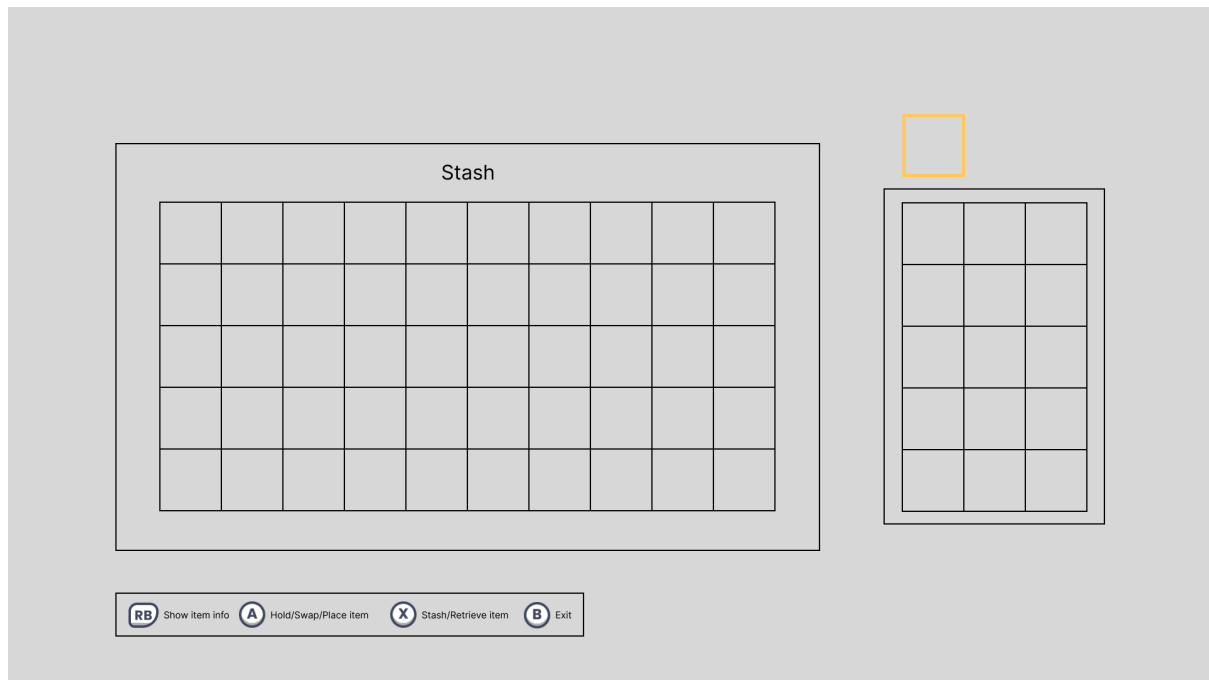

The Base Stash serves as a central repository for players to store and manage their collected items and resources. It is designed for ease of use, enabling players to efficiently organize their in-game inventory.

The movement and item interactions work the same as the inventory but there's a new functionality: "Stash/retrieve item". When pressing "X" the player can move the hovered item from the inventory directly to the first empty slot of the stash. If the hovered item is from the stash, it retrieves the hovered item to the first empty slot of the inventory. If there's no empty slots in any of the two cases (Stashing or Retrieving), nothing will happen and an error sound will be played.

When an item is moved by using the X button, the hover does not move from the original item slot location.

The player can manually stash items by selecting and placing them on an empty slot.

The player can move the hover between the inventory and the stash by.

7.9 Die Screen

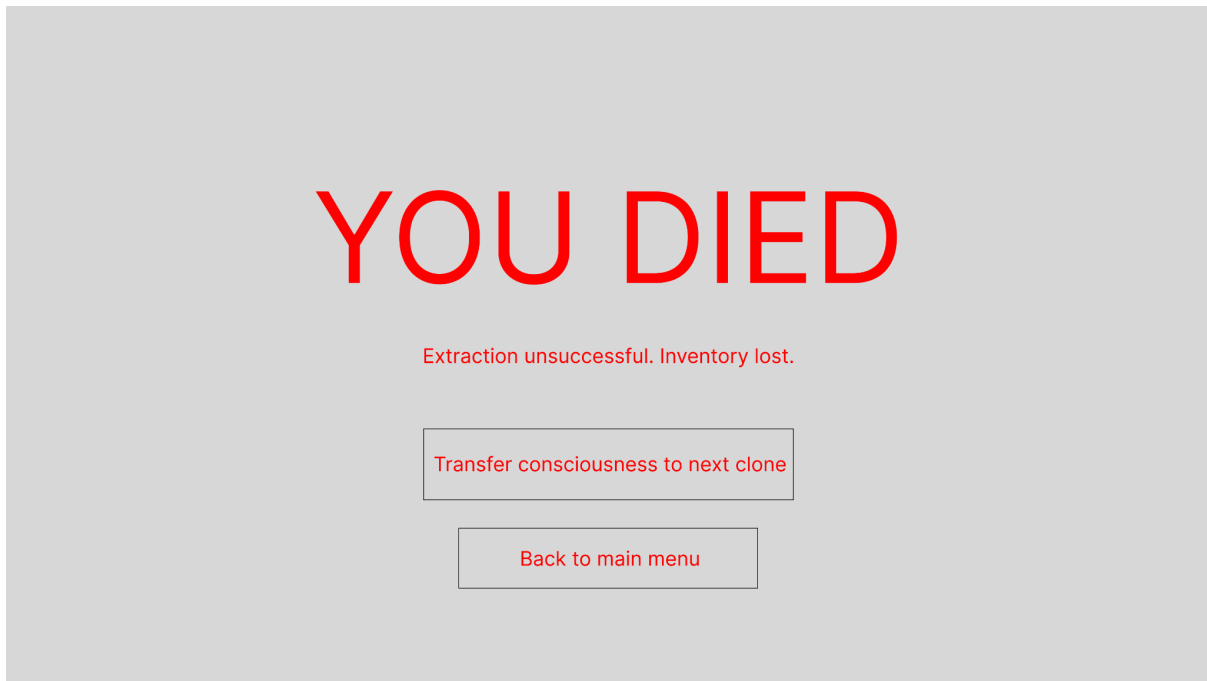

- **Central message:** Dominating the center of the screen in large, unmistakable letters, the message "YOU DIED" serves as the focal point, instantly conveying the player's defeat. The size and prominence of this message ensure it's the first element players notice, starkly highlighting the game's cessation due to death.
- **Cause of death description:** Directly beneath the central message, a smaller, detailed description provides context for the player's death. This could include reasons such as "Extraction was not successful, and inventory has been lost," or "Defeated by an enemy," offering a brief retrospective on what led to the game over scenario. This section helps players understand their mistakes, potentially guiding future strategies.

Resurrection Options: Further down, the UI presents two distinct paths forward, represented by buttons within the interface:

- **Transfer consciousness:** One button allows the player to "Transfer consciousness to the next clone," effectively resurrecting the player at the base for another attempt at the mission. This option emphasizes the game's continuity and the possibility of overcoming previous failures.
- **Main menu:** The alternative button directs players back to the main menu, providing an opportunity to pause, adjust settings, or exit the game.

Aesthetic Elements: The Die Screen should be enhanced with visual elements that underscore the game over theme. This could include:

- **Red color scheme:** Utilizing shades of red to paint a visual picture of danger and termination, imbuing the screen with a sense of urgency and loss. Or just HUD in red.
- **Particles and animations:** Subtle animations or particle effects.
- **Sound effects:** Accompanying sound effects or a brief, somber musical score could further immerse players in the moment, marking the end of their current journey with auditory cues that evoke emotion and reflection.

7.10 Pause Screen

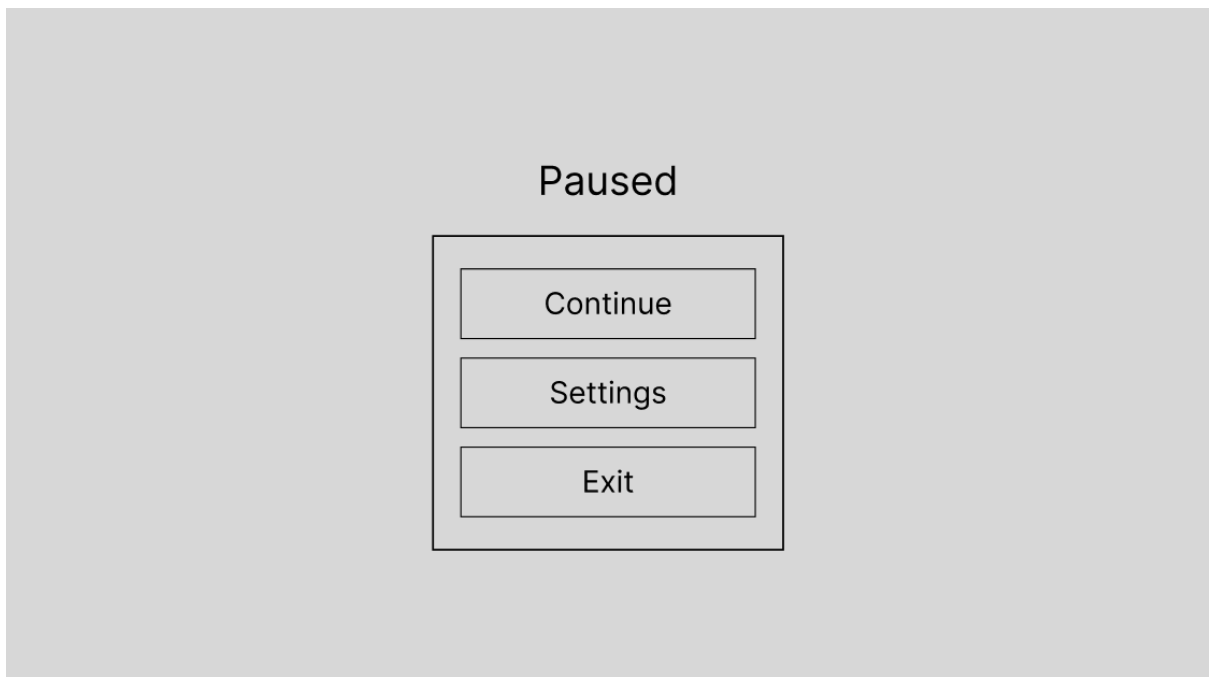

- **Continue:** Resumes the game from where it was paused.
- **Settings:** Access from within the game for adjustments on the fly.
- **Exit:** Return to the main menu to access global game options or exit the game.

7.11 Global Game Menu Flow

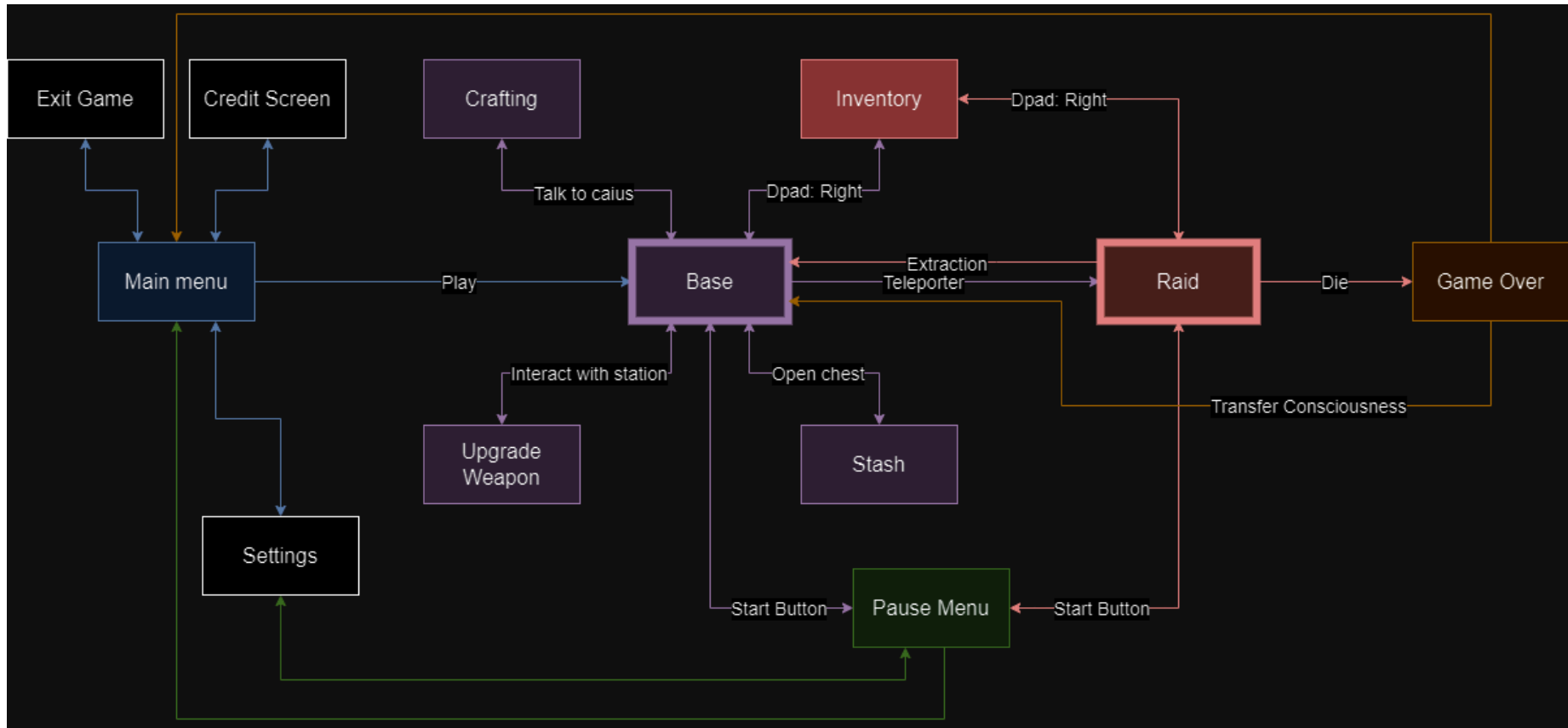

In this diagram we can see the global game menu flow as well as a text indicating how to access each menu.

The 'Base' and 'Raid' rectangles are not menus, these are game states.

If the arrow is double sided, it means the player can go back and forth between the menus/game states. For example: in raid, the player can access the inventory and then go back to the gameplay in the raid so the arrow that connects these to options is double sided.

- **Main menu accessibility:**
 - From the main menu, players have several options:
 - **Exit game:** Directly exit to the desktop, seamlessly closing the game.
 - **Credits screen:** View the game's credits, acknowledging the team behind the game.
 - **Settings:** Access game settings where players can adjust controls, audio, video, and other preferences.
 - **Play:** Initiating gameplay takes players directly to the base, where they can interact with game characters, manage inventory, and prepare for raids.

- **Base interactions:**
 - Within the base, players have multiple interaction points:
 - **Crafting:** Talking to Caius opens the crafting screen, allowing players to craft items with collected materials.
 - **Weapon upgrades:** Interacting with the designated station in the base brings up the weapon upgrade screen.
 - **Stash access:** Opening the chest in the base leads to the stash screen for inventory management.
 - **Inventory management:** Using the right D-pad button opens the inventory screen directly from the base.
 - **Pause menu:** Pressing the start button in the base opens the pause menu, offering settings access and the option to return to the main menu.

- **Raid access:**
 - From the base, using the teleporter initiates a raid, transporting players to their selected level for gameplay.

- **In-Raid options:**
 - **Extraction:** Players can use the extraction option to return to the base.
 - **Inventory and pause:** Within a raid, the right D-pad button opens the inventory, and the start button opens the pause menu with options to continue, access settings, or return to the main menu.
 - **Game over:** Upon death, players are taken to the Game Over screen.

- **Pause menu navigation:**
 - **Continue:** Resumes the game from where it was paused.
 - **Settings:** Access from within the game for adjustments on the fly.
 - **Exit:** Return to the main menu to access global game options or exit the game.

- **Game over screen:**
 - Offers options to return to the main menu or "transfer consciousness" to another android, allowing players to continue their adventure from the base without losing progress.

8. Audio

8.1 Audio Pilar

The audio in the game will have a relative focus on realism, mixing with the retro-futuristic and sci-fi feel the Alien series has. The reason behind this is due to the IP (Alien saga) and the genre of our game, we are not afraid of breaking immersion but at the same time we want the player to feel and be a part of the atmosphere designed for the game, moreover, following this line we can be relatively creative with the sound design.

8.2 Required assets

SFX: Sound effects, as well as the music, will be properly sourced (if it's copyright protected) and will tend to be a mix of retro-realism. As a whole there will be SFX for: the player, the NPC's, the enemies, all the levels and instances and UI (including game menu). Since all the audios are indoors, they must have a reverb, especially the louder ones, such as those of the treble or those of the enemies. Depending on the surface that the player is trembling, a different pass sound is produced.

Music: The game will have background music on a couple of different levels (Base & Level 3) as well as combat music in all of them. This music will mostly be copyright-free, unless some that will be properly sourced at the credits of the game. Our music, in general, will have a tense and mysterious feel to it, alongside with the combat music that will endorse this tension throughout the game levels and bossfight.

All the SFX and Music is sourced and not self produced.









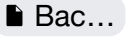
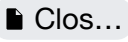

Technical features

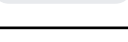
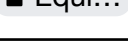
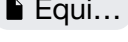

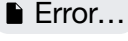

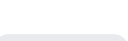
For all SFX & music:

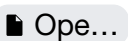
- **Sample Rate: 48 KHz**
- **Bits: 16 bits**
- **Channels: 2 (Stereo)**
- **Format: WAV**

All SFX will last on average 1 second or less. Some will last at most 2 seconds.



List of SFX







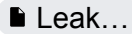
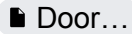
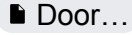
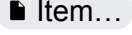

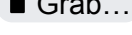
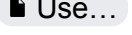
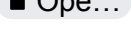
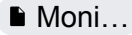
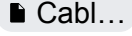
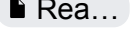
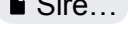
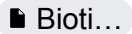
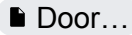





Event	Asset	Description	Reference	Loop
UI				
UI_Back	SFX_UI_Back.wav	Go back on the menu.	 Bac...	No
UI_CloseMap	SFX_UI_CloseMap.wav	Close the map.	 Clos...	No
UI_Craft	SFX_UI_Craft.wav	Item is crafted.	 Craft...	No
UI_EquipArmor	SFX_UI_EquipArmor.wav	Armor is equipped.	 Equi...	No
UI_EquipChip	SFX_UI_EquipChip.wav	Chip is equipped.	 Equi...	No
UI_EquipConsumable	SFX_UI_EquipConsumable.wav	Consumable is equipped.	 Equi...	No
UI_Error	SFX_UI_Error.wav	When the player attempts to perform an action that is not possible (such as equipping something that cannot be equipped in that slot).	 Error...	No
UI_MoveHover	SFX_UI_Move.wav	Move the UI hover (what sounds when you scroll through the buttons with the controller).	 Mov...	No
UI_OpenInventory	SFX_UI_OpenInventory.wav	Open the inventory.	 Ope...	No
UI_OpenMap	SFX_UI_OpenMap.wav	Open the map.	 Ope...	No
UI_OpenMenu	SFX_UI_OpenMenu.wav	Open the pause menu.	 Ope...	No
UI_PlaceItem	SFX_UI_PlaceItem.wav	Place an item in the inventory, in the stash, in the equipment or in the crafting area.	 Plac...	No
UI_SelectItem	SFX_UI_SelectItem.wav	Select an item.	 Sele...	No
UI_SelectSomething	SFX_UI_Select.wav	Select any button in the UI (such as select level,	 Sele...	No















Event	Asset	Description	Reference	Loop
		weapon, something in the pause menu, an option in the dialog).		
UI_SkillOnCD	SFX_UI_SkillCD.wav	Attempting to use a skill on cooldown.	 Skill...	No
UI_Start	SFX_UI_Start.wav	Start playing.	 Start...	No
UI_SwapConsumables	SFX_UI_SwapConsumables.wav	Changing consumables in battle.	 Swa...	No
UI_WeaponUpgrade	SFX_UI_WeaponUpgrade.wav	Improve the weapon.	 Wea...	No
Main Character: Raisen				
P_Hit	SFX_ANIM_CHAR_Hit_Raisen.wav	Raisen gets hit.		No
P_Relief	SFX_CHAR_Relief_Raisen.wav	A soft sound Raisen does as relief when healed.		No
P_Whine	SFX_CHAR_Whine_Raisen.wav	A hard breathing when Raisen is below half HP.		Yes
P_Dash	SFX_ANIM_CHAR_Dash_Raisen.wav	Raisen dash.		No
P_AcidSpit	SFX_ANIM_CHAR_AcidSpit_Raisen.wav	Raisen Acid Spit.		No
P_AcidSpitHit	SFX_ANIM_CHAR_AcidHit_Raisen.wav	When Raisen Acid Spit hits.		No
P_AcidSpitPuddle	SFX_ANIM_CHAR_AcidPuddle_Raisen.wav	The puddle after Acid Spit hits.		No
P_TailSweep	SFX_ANIM_CHAR_TailSweep_Raisen.wav	Raisen Tail Sweep without hitting.		No
P_TailSweepHit	SFX_ANIM_CHAR_TailHit_Raisen.wav	Raisen Tail Sweep when hitting an enemy.		No
P_Death	SFX_ANIM_CHAR	Raisen defeated.		No





Event	Asset	Description	Reference	Loop
	_Death_Raisen.wav			
NPC: Iscariot				
I_Talk	SFX_ANIM_CHAR_Talk_Iscariot.wav	A broken TV/Alien-like sound when Iscariot talks.		Yes
NPC: Caius				
C_Talk	SFX_ANIM_CHAR_Talk_Caius1.wav	Robot or antic computer sounds when Caius talks.		Yes
C_Confirm	SFX_ANIM_CHAR_Confirm_Caius.wav	Caius confirm sound.		No
Weapons: Firearm				
W_FirearmShot	SFX_Weapon_FirearmShot.wav	Firearm shot sound.		Yes
W_FirearmReload	SFX_Weapon_FirearmReload.wav	Firearm reload sound.		No
W_FirearmEnemy	SFX_Weapon_FirearmHit.wav	Sound when enemy receives a shot from the firearm.		No
W_Firearm_Up	SFX_Weapon_FirearmUpgradeShot1.wav	Firearm level 1 shot sound.		Yes
W_Firearm_Up2	SFX_Weapon_FirearmUpgradeShot2.wav	Firearm level 2 & 3 shot sound.		Yes
Weapons: FSAD				
W_FSADShot	SFX_Weapon_FSADShot.wav	FSAD shot sound.		No
W_FSADReload	SFX_Weapon_FSADReload.wav	FSAD reload sound.		No
W_FSADEnemy	SFX_Weapon_FSADHit.wav	Sound when enemy receives a shot from the FSAD.		No
W_FSADUpShot	SFX_Weapon_FSADUpgradeShot1.wav	FSAD level 2 & 3 shot sound.		No

Event	Asset	Description	Reference	Loop
Weapons: Plasma				
W_PlasmaShot	SFX_Weapon_PlasmaShot.wav	Plasma shot sound.		Yes
W_PlasmaReload	SFX_Weapon_PlasmaReload.wav	Plasma reload sound.		No
W_PlasmaEnemy	SFX_Weapon_PlasmaSurface&Hit.wav	Sound when enemy receives a shot from the plasma weapon.		No
W_PlasmaShot1	SFX_Weapon_PlasmaShot2.wav	Plasma level 2 shot sound.		Yes
W_PlasmaShot2	SFX_Weapon_PlasmaShot3.wav	Plasma level 3 shot sound.		Yes
World: Base				
B_Consoles	SFX_Environment_Monitors.wav	Computer and consoles.	Moni...	Yes
B_CablesSpurt	SFX_Environment_Cables.wav	Broken cables spurting electricity.	Cabl...	Yes
B_AirCond	SFX_Environment_AirConditioning.wav	Air Conditioning fan.	AirC...	Yes
B_Metal	SFX_Environment_Metal2.wav	Walking on metal.		Yes
B_OpenDoor	SFX_Interaction_DoorOpen.wav	Opening air pressured doors.	Door...	No
B_CloseDoor	SFX_Interaction_DoorClose.wav	Closing air pressured doors.	Door...	No
B_Teleport	SFX_Interaction_Beacon.wav	Teleport usage.	Bea...	No
World: Level 1 - The warehouse				
LV1_Machinery	SFX_Environment_Machinery.wav	Industrial sounds in the distance.	Mac...	Yes
LV1_CablesSpurt	SFX_Environment_Cables.wav	Broken cables spurting electricity.	Cabl...	Yes
LV1_Fire	SFX_Environment_Fire.wav	Burning.	Fire....	Yes

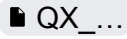
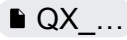
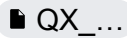
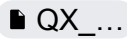

Event	Asset	Description	Reference	Loop
LV1_LeakPipes	SFX_Environment_LeakingPipe.wav	Liquid drops leaking from pipes.	 Leak...	Yes
LV1_Ashes	SFX_Environment_Ashes2.wav	Walking on ashes.		Yes
LV1_Metal	SFX_Environment_Metal2.wav	Walking on metal.		Yes
LV1_OpenDoor	SFX_Interaction_DoorOpen.wav	Opening air pressured doors.	 Door...	No
LV1_CloseDoor	SFX_Interaction_DoorClose.wav	Closing air pressured doors.	 Door...	No
LV1_CollectItem	SFX_Interaction_ItemPickup.wav	Raisen collects an item.	 Item...	No
LV1_Beacon	SFX_Interaction_Beacon.wav	Beacon usage.	 SFX...	Yes
LV1_GrabKey	SFX_Interaction_GrabKey.wav	Raisen collects a key.	 Grab...	No
LV1_UseKey	LV1_UseKey.wav	Raisen uses a key.	 Use...	No
LV1_OpenChest	SFX_Interaction_OpenChest.wav	Raisen opens a metal chest.	 Ope...	No
World: Level 2 - The lab				
LV2_Consoles	SFX_Environment_Monitors.wav	Computer and consoles.	 Moni...	Yes
LV2_CablesSpurt	LV2_CablesSpurt.wav	Broken cables spurting electricity.	 Cabl...	Yes
LV2_Reactor	SFX_Environment_Reactor.wav	Reactor beaming and in full use.	 Rea...	Yes
LV2_Siren	SFX_Environment_Siren.wav	Siren when LV2 main door closes.	 Sire...	Yes
LV2_BioticLT	SFX_Environment_BioticLiquidTank.wav	Cylindrical containers from which bubbles are audible.	 Bioti...	Yes
LV2_Metal	SFX_Environment_Metal1.wav	Walking on metal.		Yes
LV2_OpenDoor	SFX_Interaction_DoorOpen.wav	Opening air pressured doors.	 Door...	No





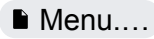
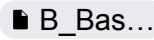

Event	Asset	Description	Reference	Loop
LV2_CloseDoor	SFX_Interaction_DoorClose.wav	Closing air pressured doors.	 Door...	No
LV2_CollectItem	SFX_Interaction_ItemPickup.wav	Raisen collects an item.	 Item...	No
LV2_Beacon	SFX_Interaction_Beacon.wav	Beacon usage.	 Bea...	No
LV2_GrabKey	SFX_Interaction_GrabKey.wav	Raisen collects a key.	 Grab...	No
LV2_UseKey	SFX_Interaction_UseKey.wav	Raisen uses a key.	 Use...	No
LV2_OpenChest	SFX_Interaction_OpenChest.wav	Raisen opens a metal chest.	 Ope...	No
World: Level 3 - The hatchery				
LV3_Stone	SFX_Environment_Bone1.wav	Walking on bone/stone		Yes
LV3_Veins	SFX_Environment_Veins.wav	Blood flows from The Hatchery walls.	 Vein...	Yes
LV3_HeartBeats	SFX_Environment_Heartbeat.wav	The Hatchery heartbeating.	 Hear...	Yes
LV3_DistAlienCry	SFX_Environment_DistantCry.wav	Ambient exploration sound.	 Cry....	No
LV3_Flesh	SFX_Environment_Flesh2.wav	Walking on flesh.		Yes
LV3_OpenDoor	SFX_Interaction_DoorOpenFlesh.wav	Opening air pressured doors.	 Door...	No
LV3_CloseDoor	SFX_Interaction_DoorCloseFlesh.wav	Closing air pressured doors.	 Door...	No
LV3_CollectItem	SFX_Interaction_ItemPickup.wav	Raisen collects an item.	 Item...	No
LV3_Beacon	SFX_Interaction_Beacon.wav	Beacon usage.	 Bea...	Yes
LV3_GrabKey	SFX_Interaction_GrabKey.wav	Raisen collects a key.	 Grab...	No
LV3_UseKey	SFX_Interaction_UseKey.wav	Raisen uses a key.	 Use...	No

Event	Asset	Description	Reference	Loop
LV3_OpenChest	SFX_Interaction_OpenChestFlesh.wav	Raisen opens a metal-fleshy chest.	 Ope...	No
Enemies: Facehugger				
FH_Move	SFX_ANIM_ENEMY_FH_Move.wav	Facehugger movement.	 FH_...	Yes
FH_Cry	SFX_ANIM_ENEMY_FH_Cry.wav	Facehugger high-pitched cry.	 FH_...	No
FH_Tail	SFX_ANIM_ENEMY_FH_Tail.wav	Facehugger tail hit attack.	 FH_...	No
FH_Death	SFX_ANIM_ENEMY_FH_Death.wav	Facehugger defeated.	 FH_...	No
Enemies: Drone xenomorph				
DX_Move	SFX_ANIM_ENEMY_DX_Move.wav	Drone xenomorph movement.	 DX_...	Yes
DX_Cry	SFX_ANIM_ENEMY_DX_Cry.wav	Drone xenomorph deafening cry.	 DX_...	No
DX_Claw	SFX_ANIM_ENEMY_DX_Claw.wav	Drone xenomorph claw attack.	 DX_...	No
DX_Tail	SFX_ANIM_ENEMY_DX_Tail.wav	Drone xenomorph tail thrust attack.	 DX_...	No
DX_Death	SFX_ANIM_ENEMY_DX_Death.wav	Drone xenomorph defeated.	 DX_...	No
Enemies: Xeno spitter				
XS_Move	SFX_ANIM_ENEMY_XS_Move.wav	Xeno spitter movement.	 XS_...	Yes
XS_Cry	SFX_ANIM_ENEMY_XS_Cry.wav	Xeno spitter deafening cry.	 XS_...	No
XS_Spit	SFX_ANIM_ENEMY_XS_Spit.wav	Xeno spitter rapid acid spit attack.	 XS_...	No
XS_Rebound	SFX_ANIM_ENEMY_XS_Rebound.wav	Xeno spitter acid spit attack.	 XS_...	No
XS_Death	SFX_ANIM_ENEMY_XS_Death.wav	Xeno spitter defeated.	 XS_...	No
Boss: Queen xenomorph				

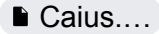
Event	Asset	Description	Reference	Loop
QX_Move	SFX_ANIM_ENEMY_QX_Move.wav	Queen xenomorph movement.	 QX_...	Yes
QX_Cry	SFX_ANIM_ENEMY_QX_Cry.wav	Queen xenomorph, loud deafening cry.	 QX_...	No
QX_Acid	SFX_ANIM_ENEMY_QX_Acid.wav	Queen xenomorph huge acid spit attack.	 QX_...	No
QX_Puddle	SFX_ENEMY_QX_Puddle.wav	Queen xenomorph acid puddle.	 QX_...	No
QX_Claw	SFX_ANIM_ENEMY_QX_Claw.wav	Queen xenomorph huge claw attack.	 QX_...	No
QX_TailMove	SFX_ANIM_ENEMY_QX_TailMove.wav	Queen xenomorph tail move.	 QX_...	No
QX_TailHit	SFX_ANIM_ENEMY_QX_TailHit.wav	Queen xenomorph giant tail hit attack.	 QX_...	No
QX_Death	SFX_ANIM_ENEMY_QX_Death.wav	Queen xenomorph defeated.	 QX_...	No

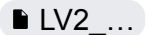
List of Music

Event	Asset	Description	Reference	Loop
UI				
UI_Menu	SOT_Menu.wav	Music that plays when the game opens. It starts with a calm tone and gradually escalates to a more intense one.	 Menu....	Yes
World: Base				
B_Basic	SOT_Environment_Base.wav	Very calm song, letting us understand that there is no danger in that area. A piano stands out above the rest.	 B_Bas...	Yes
B_Departing	SOT_Departing_Base.wav	Song composed mostly by percussion. It works as an introduction to the adventure that the player is	 Deapar...	Yes

		going to live. Epic but in a moderate way.		
B_Caius	SOT_CHAR_Caius.wav	Song with retro sounds characteristic of arcade machines. Gives a casual atmosphere.		Yes
World: Level 1 - The warehouse				
LV1_Combat	SOT_Combat_LV1.wav	Quite soft as it is the first level, but adding more intense sounds.		Yes
World: Level 2 - The lab				
LV2_Combat	SOT_Combat_LV2.wav	Combat music with lots of percussion and electronic tones to emphasize the atmosphere of level 2.		Yes
LV2_Inter	SOT_Intersection_LV2.wav	Calm song which could be defined as “elevator music”, for a room without enemies and a little break from the action.		Yes
World: Level 3 - The hatchery				
LV3_Basic	SOT_Environment_LV3.wav	This song tries to convey a sense of tension, without too many variations throughout the song.		Yes
LV3_Combat	SOT_Combat_LV3.wav	Tense song with sounds that add an aggressive point to the main melody.		Yes
LV3_Boss	SOT_Bossfight_LV3.wav	More epic song. It has a calmer beginning but it scales very fast in intensity and rhythm in accordance with the battle with the final boss.		Yes

8.3 Planning

Tasks & workflow

The way the audio section is distributed in the project subject, the design department is in charge of researching and searching for audios, editing and implementing them in Wwise. Once this is done, there is a person from the code department in charge of the implementation of these in the game.

The deadlines of the project are as follows:

Assignment	Date	Objectives
Concept Discovery	February 23th	Listing and definition of all audios.
Vertical Slice 1	March 8th	First search for placeholders.
Vertical Slice 2	March 22th	Audios of the main character, base weapons and level 2.
Alpha 1	April 12th	Audios of Facehugger, Drone Xenomorph, UI, level 1 and base.
Alpha 2	April 26th	Audios for Xeno Spitter, consumables and NPCs.
Alpha 3	May 10th	Audios for upgraded weapons, level 3 and Queen Xenomorph.
Beta	May 24th	Voice-over.
Gold	June 12th	Necessary finishing touches.

The corresponding tasks of each person will be distributed in the different tables of each milestone of the HacknPlan project.

Priorities

- The highest priority assets would be the SFX of the main character, the enemies and the background music.
- Next would be the SFX of the UI and environment.

8.4 Integration & implementation

Integration description

- **Target hardware:** PC
- **Software:**
 - Game engine: YmirEngine
 - Middleware: Wwise
- **Sound output features:**
 - Speaker type: Stereo, Headphones
 - Sampling rate: 48 kHz
 - Bitrate: 16 bits
- **Platform limits:**
 - Audio format: WAV

Implementation

Once the audios have been edited and passed through the editing phase, they have to be entered into Wwise in order to be transferred to the engine. The steps for entering them into Wwise are as follows:

- Enter the SFX or music into Wwise.
- Create an event for each SFX or music. When calling an SFX or music from the engine, the name of the event will be used.
- A soundbank is created where the events will be separated by categories (player, level 1, ...).

After this, everything is exported and passed to the engine.

